

Service Manual

Cassette Deck

RS-M226

(Black Face)
(Silver Face)

Soft-Touch Cassette
Deck with Dolby B-C NR



This is the Service Manual for the following areas.

- For all European areas
except United Kingdom.
 For United Kingdom.

Please use this service manual for the RS-M226. (Discard the service manual prepared for the order No. ARD82050142C8-11.)

RS-M24 MECHANISM SERIES

Specifications

Track system:	4-track 2-channel stereo recording and playback	Inputs:	MIC; sensitivity 0.25 mV, applicable microphone impedance, 400 Ω —10 k Ω LINE; sensitivity 60 mV, input impedance more than 47 k Ω
Tape speed:	4.8 cm/s	Outputs:	LINE; output level 400 mV, output impedance less than 2.3 k Ω HEADPHONES; output level 80 mV (8 Ω) applicable headphone impedance 8 Ω —600 Ω
Wow and flutter:	0.048% (WRMS), \pm 0.14% (DIN)	Bias frequency:	80 kHz
Frequency response:	Metal tape; 20—18,000 Hz 30—17,000 Hz (DIN) CrO ₂ tape; 20—18,000 Hz 30—16,000 Hz (DIN) Normal tape; 20—17,000 Hz 30—15,000 Hz (DIN)	Motor:	Electrical DC governor motor
Signal-to-noise ratio:	Dolby [*] C NR in; 75 dB (CCIR) Dolby B NR in; 67 dB (CCIR) NR out; 57 dB (signal level = max. input level A weighted, CrO ₂ type tape)	Heads:	2-head system 1 MX head for rec/playback 1 double-gap ferrite head for erasure
Fast forward and rewind time:	Approx. 90 seconds with C-60 cassette tape	Power requirements:	<input type="checkbox"/> ... AC 220 V, 50-60 Hz (for all European areas except United Kingdom.) <input type="checkbox"/> ... AC 240 V, 50 Hz (only for United Kingdom.)
		Power consumption:	12 W
		Dimensions:	43.0 cm(W) \times 10.9 cm(H) \times 23.3 cm(D)
		Weight:	4.0 kg

Specifications are subject to change without notice.

* 'Dolby' and the double-D symbol are trademarks of Dolby Laboratories.

Technics

Matsushita Electric Trading Co., Ltd.
P.O. Box 288, Central Osaka Japan

CONTENTS

ITEM	PAGE	ITEM	PAGE
LOCATION OF CONTROLS AND COMPONENTS	2	BLOCK DIAGRAM	9
DISASSEMBLY INSTRUCTIONS	2	SCHEMATIC DIAGRAM	13
MEASUREMENT AND ADJUSTMENT METHODS	3	CIRCUIT BOARDS AND WIRING CONNECTION DIAGRAM	15
ELECTRICAL PARTS LOCATION	8	MECHANICAL PARTS LOCATION	18
		CABINET PARTS LOCATION	22

LOCATION OF CONTROLS AND COMPONENTS

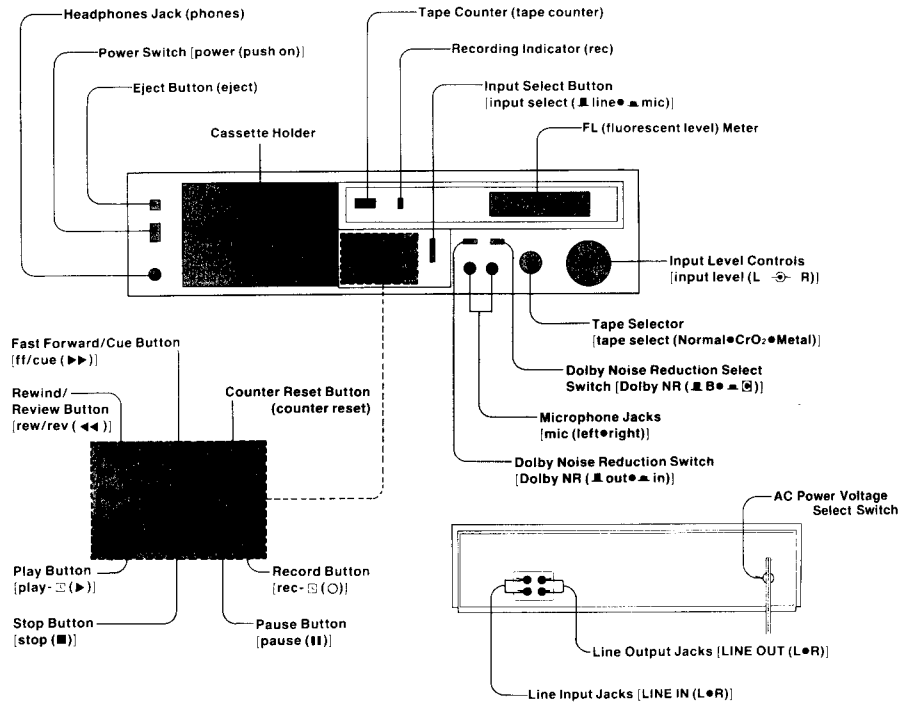

DISASSEMBLY INSTRUCTIONS

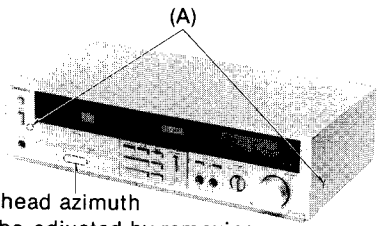

Fig. 1

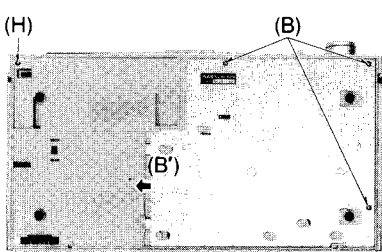

Fig. 2

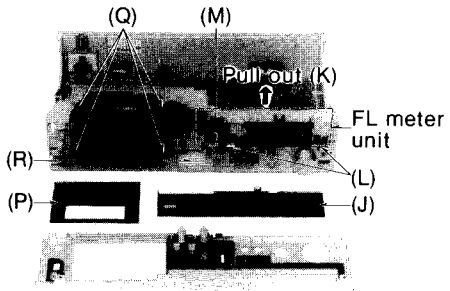

Fig. 4

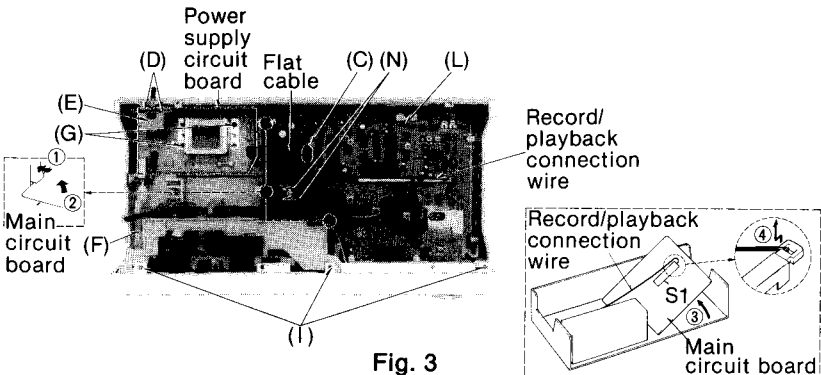

Fig. 3

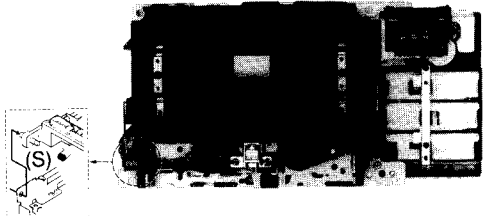

Fig. 5

Ref. No.	Procedure	To remove ——— .	Remove ——— .	Shown in fig. ——— .
1	1	Case cover	• 2 screws(A)	1
2	2	Bottom cover	• 3 screws(B) (Slide in direction of arrow).....(B')	2
3	1→3	Power supply circuit board	• Pull out the flat cable from connector [4](C) • 2 screws(D) • Cord clasper(E) • Pull out the switch rod-C(F) • 2 red screws.....(G)	3 3 3 3 3
4	1→2→4	Front panel	• 1 screw.....(H) • 3 screws(I)	2 3
5	1→2→4→5	FL meter unit	• Meter cover and meter filter(J) • Pull out the FL meter unit(K)	4 4
6	1→2→4→5→6	Main circuit board	• 3 red screws.....(L) • Pull out the switch rod-E(M) • Pull out the flat cable from connector [4](C) • Pull out the socket(N) • As shown in fig. 3, push the claw in the direction of arrow ①, lift the main circuit board in the direction of arrow ②. • Remove the record/playback connection wire in the direction of arrow ④ while lifting the main circuit board in the direction of arrow ③ as shown in fig. 3.(O)	3, 4 4 3 3 3 3
7	1→2→4→5→7	Mechanism unit	• Cassette lid(P) • 4 red screws.....(Q) • Pull out the counter reset lever.....(R)	4 4 4
8	1→2→4→5→7→8	Cassette holder	• Slide in direction of arrow.....(S)	5

MEASUREMENT AND ADJUSTMENT METHODS

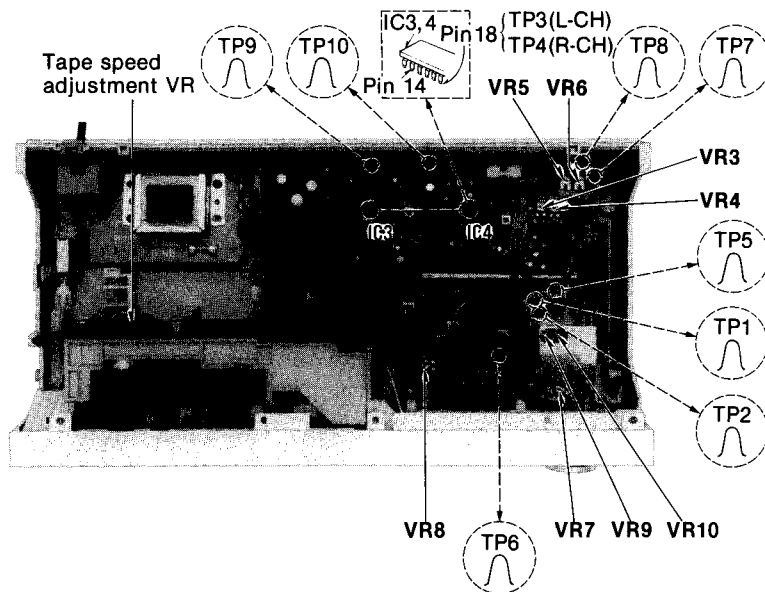
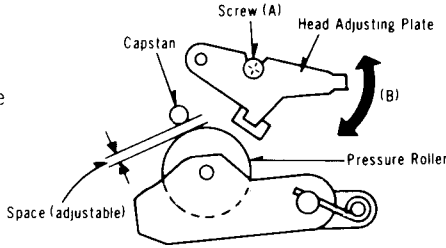
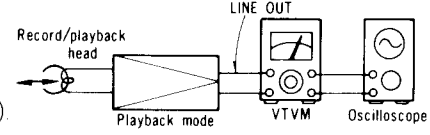
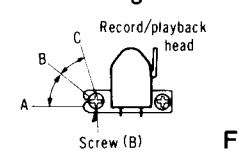
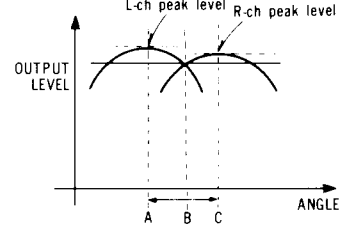

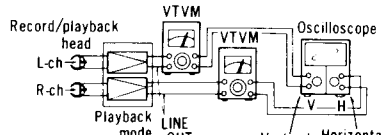
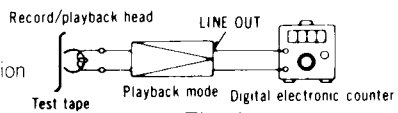

Fig. 1

NOTES: Keep good condition, set switches and controls in the following positions, unless otherwise specified.

- Make sure heads are clean.
- Make sure capstan and pressure roller are clean.
- Judgeable room temperature: 20 ± 5°C (68 ± 9°F)
- Dolby NR switch: OUT
- Tape selector: Normal position
- Input selector: Line in
- Input level controls: Maximum

ITEM	MEASUREMENT & ADJUSTMENT
<p>A Head position adjustment</p> <p>Condition:</p> <ul style="list-style-type: none"> • Playback and pause mode 	<p>(The head adjusting plate is provided to adjust the tape touch of the head in cue or review mode)</p> <ol style="list-style-type: none"> 1 Press the playback button and pause button 2 Measure the space between the pressure roller and the capstan. <div style="border: 1px solid black; padding: 5px; width: fit-content; margin: 10px auto;"> <p>Standard value: 0.5 ± 0.3mm</p> </div> <ol style="list-style-type: none"> 3 If the measured value is not within the standard value, untighten screw (A), and slide the head adjusting plate in the direction of arrow (B) for adjustment  <p style="text-align: center;">Fig. 2</p>
<p>B Head azimuth adjustment</p> <p>Condition:</p> <ul style="list-style-type: none"> • Playback mode <p>Equipment:</p> <ul style="list-style-type: none"> • VTVM • Oscilloscope • Test tape (azimuth) ... QZZCFM 	<p>L-ch/R-ch output balance adjustment</p> <ol style="list-style-type: none"> 1 Make connections as shown in fig. 3. 2 Playback the 8kHz signal from the test tape (QZZCFM). Adjust screw (B) in fig. 4 for maximum output L-ch and R-ch levels. <p>When the output levels of L-ch and R-ch are not at maximum at the same time, readjust as follows.</p> <ol style="list-style-type: none"> 3 Turn the screw shown in fig. 4 to find angles A and C (points where peak output levels for left and right channels are obtained). Then, locate the angle B between angles A and C, i.e., a point where L-ch and R-ch output levels come together at maximum. (Refer to figs. 4 and 5.) <p>L-ch/R-ch phase adjustment</p> <ol style="list-style-type: none"> 4 Make connections as shown in fig. 6. 5 Playback the 8kHz signal from the test tape (QZZCFM). Adjust screw (B) shown in fig. 4 so that pointers of the two VTVMs swing to maximum and a waveform as illustrated in fig. 7 is obtained on the oscilloscope.  <p style="text-align: center;">Fig. 3</p>  <p style="text-align: center;">Fig. 4</p>  <p style="text-align: center;">Fig. 5</p>  <p style="text-align: center;">Fig. 7</p>  <p style="text-align: center;">Fig. 6</p>
<p>C Tape speed</p> <p>Condition:</p> <ul style="list-style-type: none"> • Playback mode <p>Equipment:</p> <ul style="list-style-type: none"> • Digital electronic counter or frequency counter • Test tape ... QZZCWAT 	<p>Tape speed accuracy</p> <ol style="list-style-type: none"> 1 Test equipment connection is shown in fig. 8. 2 Playback test tape (QZZCWAT 3,000Hz) at middle section and supply playback signal to frequency counter. 3 Measure this frequency 4 On the basis of 3,000Hz, determine value by following formula: $\text{Tape speed accuracy} = \frac{f - 3,000}{3,000} \times 100 (\%) \quad \text{where } f = \text{measured value}$ <div style="border: 1px solid black; padding: 5px; width: fit-content; margin: 10px auto;"> <p>Standard value: ± 1.5%</p> </div> <p>Adjustment method</p> <ol style="list-style-type: none"> 1 Playback the test tape (middle) 2 Adjust so that frequency becomes 3,000Hz 3 Tape speed adjustment VR shown in fig. 1. <p>Tape speed fluctuation</p> <p>Make measurements in same manner as above (beginning, middle and end of tape), and determine the difference between maximum and minimum values and calculate as follows:</p> $\text{Tape speed fluctuation} = \frac{f_1 - f_2}{3,000} \times 100 (\%) \quad f_1 = \text{maximum value, } f_2 = \text{minimum value}$ <div style="border: 1px solid black; padding: 5px; width: fit-content; margin: 10px auto;"> <p>Standard value: Less than 1%</p> </div> <p>Note:</p> <p>Please use non metal type screwdriver when you adjust tape speed accuracy on this unit.</p>  <p style="text-align: center;">Fig. 8</p>

ITEM	MEASUREMENT & ADJUSTMENT
<p>㊦ Playback frequency response</p> <p>Condition:</p> <ul style="list-style-type: none"> • Playback mode • Tape selector ... Normal position <p>Equipment:</p> <ul style="list-style-type: none"> • VTVM • Oscilloscope • Test tape ... QZZCFM 	<ol style="list-style-type: none"> 1. Test equipment connection is shown in fig. 3. 2. Place UNIT into playback mode 3. Playback the frequency response test tape (QZZCFM). 4. Measure output level at 315Hz, 12.5kHz, 8kHz, 4kHz, 1kHz, 250Hz, 125Hz and 63Hz, and compare each output level with the standard frequency 315Hz, at LINE OUT. 5. Make measurement for both channels. 6. Make sure that the measured value is within the range specified in the frequency response chart (shown in fig. 9). <div data-bbox="917 230 1441 510" style="text-align: center;"> <p>Playback frequency response chart</p> </div> <p style="text-align: center;">Fig. 9</p>
<p>㊦ Playback gain</p> <p>Condition:</p> <ul style="list-style-type: none"> • Playback mode • Tape selector ... Normal position <p>Equipment:</p> <ul style="list-style-type: none"> • VTVM • Oscilloscope • Test tape ... QZZCFM 	<ol style="list-style-type: none"> 1. Test equipment connection is shown in fig. 3. 2. Playback standard recording level portion on test tape (QZZCFM 315Hz), and using VTVM measure the output level at LINE OUT. 3. Make measurement for both channels <div data-bbox="528 712 1410 779" style="border: 1px solid black; padding: 5px; text-align: center;"> <p>Standard value: 455 mV ± 1 dB [around 280 mV: at test points TP3 (L-CH) and TP4 (R-CH)]</p> </div> <p>Adjustment</p> <ol style="list-style-type: none"> 1. If measured value is not within standard, adjust VR3 (L-CH), VR4 (R-CH) (See fig. 1 on page 3). 2. After adjustment, check "Playback frequency response" again
<p>㊦ Erase current</p> <p>Condition:</p> <ul style="list-style-type: none"> • Record mode • Tape selector ... Metal position <p>Equipment:</p> <ul style="list-style-type: none"> • VTVM • Oscilloscope 	<ol style="list-style-type: none"> 1. Test equipment connection is shown in fig. 10. 2. Press the record and pause buttons 3. Set the tape selector to metal position. 4. Read voltage on VTVM and calculate erase current by following formula: <div data-bbox="571 1016 1070 1070" style="text-align: center;"> $\text{Erase current (A)} = \frac{\text{Voltage across both ends of R124}}{1 (\Omega)}$ </div> <div data-bbox="528 1088 1054 1144" style="border: 1px solid black; padding: 5px; text-align: center;"> <p>Standard value: 155 ± 15 mA (Metal position)</p> </div> <div data-bbox="1091 920 1430 1070" style="text-align: center;"> </div> <p style="text-align: center;">Fig. 10</p> <ol style="list-style-type: none"> 5. If measured value is not within standard, adjust as follows <p>Adjustment</p> <ol style="list-style-type: none"> 1. Open the point (A) and short the point (B) on the main circuit board in the wiring connection diagram (See page 15). 2. Make measurement for erase current 3. Make sure that the measured value is within the erase current of 140mA to 170mA. 4. If it is beyond the value, carry out the following adjustments: <ul style="list-style-type: none"> • If the erase current is less than 140mA, short the point (A) • If the erase current is more than 170mA, open the points (A) and (B).
<p>㊦ Overall frequency response</p> <p>Condition:</p> <ul style="list-style-type: none"> • Record/playback mode • Tape selector ... Normal position ... CrO₂ position ... Metal position • Input level controls ... MAX <p>Equipment:</p> <ul style="list-style-type: none"> • VTVM • AF oscillator • ATT • Oscilloscope • Resistor (600Ω) • Test tape (reference blank tape) ... QZZCRA for Normal ... QZZCRX for CrO₂ ... QZZCRZ for Metal 	<p>Note :</p> <p>Before measuring and adjusting, make sure of the playback frequency response (For the method of measurement, please refer to the playback frequency response).</p> <div data-bbox="938 1424 1441 1688" style="text-align: center;"> <p>Overall frequency response chart (Normal)</p> </div> <p style="text-align: center;">Fig. 11</p> <p>Overall frequency response adjustment by recording bias current</p> <p>Note 1:</p> <p>On RS-M226, overall frequency response is adjusted with tape selector set at Normal.</p> <p>Note 2:</p> <p>Recording equalizer is fixed.</p> <ol style="list-style-type: none"> 1. Make connections as shown in fig. 12. 2. Input a 1kHz, -24 dB signal through LINE IN. Place the set in record mode. 3. Fine adjust the attenuator to obtain 0.4V LINE OUT output. <ul style="list-style-type: none"> • Make sure that the input signal level is -24 ± 4 dB with 0.45V output voltage. <div data-bbox="917 1749 1430 2051" style="text-align: center;"> </div> <p style="text-align: center;">Fig. 12</p>

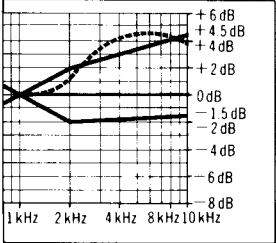
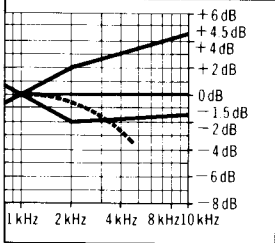
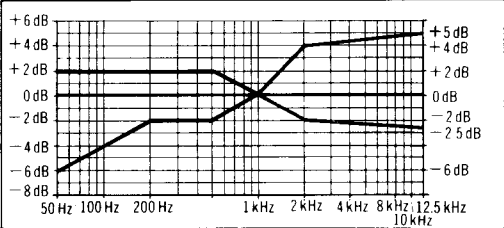
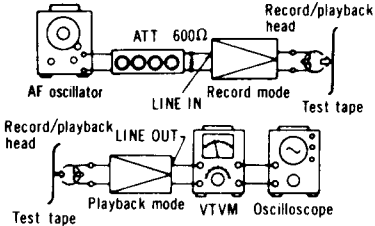
ITEM	MEASUREMENT & ADJUSTMENT
	<p>4. Set the tape selector to Normal, and load the test tape (QZZCRA).</p> <p>5. Adjust the attenuator to reduce the input signal level by 20 dB.</p> <p>6. Adjust the AF oscillator to generate 50Hz, 100Hz, 200Hz, 500Hz, 1kHz, 4kHz, 8kHz and 10kHz signals, and record these signals on the test tape.</p> <p>7. Playback the signals recorded in step 6, and check if the frequency response curve is within the limits shown in the overall frequency response chart for normal tapes (fig. 11). (If the curve is within the charted specifications, proceed to steps 8, 9 and 10.) If the curve is not within the charted specifications, adjust as follows:</p> <p>Adjustment (A): When the curve exceeds the overall frequency response chart specifications (fig. 11) as shown in fig. 13.</p>  <p>Fig. 13</p> <ol style="list-style-type: none"> 1) Increase bias current by turning VR9 (L-CH) and VR10 (R-CH). (See fig. 1 on page 3.) 2) Repeat steps 6 and 7 to confirm. (Proceed to steps 8, 9 and 10 if the curve is now within the charted specifications in fig. 11.) 3) If the curve still exceeds the specifications (fig. 11), increase bias current further and repeat steps 6 and 7. <p>Adjustment (B): When the curve falls below the overall frequency response chart specifications (fig. 11) as shown in fig. 14.</p>  <p>Fig. 14</p> <ol style="list-style-type: none"> 1) Reduce bias current by turning VR9 (L-CH) and VR10 (R-CH). 2) Repeat steps 6 and 7 to confirm. (Proceed to steps 8, 9 and 10 if the curve is now within the charted specifications in fig. 11.) 3) If the curve still falls below the charted specifications (fig. 11), reduce bias current further and repeat steps 6 and 7. <p>8. Switch the tape selector to CrO₂, change test tape to QZZCRX, and record 50Hz, 100Hz, 200Hz, 500Hz, 1kHz, 4kHz, 8kHz, 10kHz and 12.5kHz signals. Then, playback the signals and check if the curve is within the limits shown in the overall frequency response chart for CrO₂ tapes (fig. 15).</p>  <p>Fig. 15</p> <p>9. Switch the tape selector to Metal, change test tape to QZZCRZ, and record 50Hz, 100Hz, 200Hz, 500Hz, 1kHz, 4kHz, 8kHz, 10kHz and 12.5kHz signals. Then, playback the signals and check if the curve is within the limits shown in the overall frequency response chart for metal tapes (fig. 15).</p> <p>10. Confirm that bias currents are approximately as follows when the tape selector is set at different positions.</p> <ul style="list-style-type: none"> • Read voltage on VTVM and calculate bias current by following formula: $\text{Bias current (A)} = \frac{\text{Value read on VTVM (V)}}{10 (\Omega)}$ <div style="border: 1px solid black; padding: 5px; margin-top: 10px;"> <p>around 350μA (Normal position) around 450μA (CrO₂ position) around 700μA (Metal position) } : measured at TP1 (L-CH) and TP2 (R-CH)</p> </div>
<p>H Overall gain</p> <p>Condition:</p> <ul style="list-style-type: none"> • Record/playback mode • Tape selector <ul style="list-style-type: none"> Normal position • Input level controls ... MAX • Standard input level: <ul style="list-style-type: none"> MIC - 72 \pm 4 dB LINE IN ... - 24 \pm 4 dB 	<ol style="list-style-type: none"> 1. Test equipment connection is shown in fig. 16. 2. Place UNIT into record mode, and tape selector to normal position. 3. Supply 1 kHz signal (-24 dB) from AF oscillator, through ATT to LINE IN. 4. Adjust ATT until monitor level at LINE OUT becomes 0.45V. 5. Using test tape, make recording. 6. Playback recorded tape, and make sure the value at LINE OUT on VTVM becomes 0.45V.  <p>Fig. 16</p>

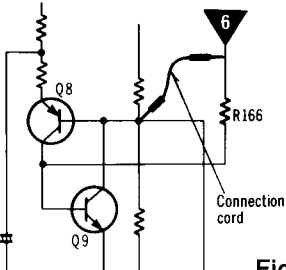
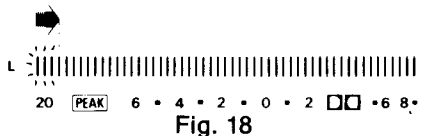
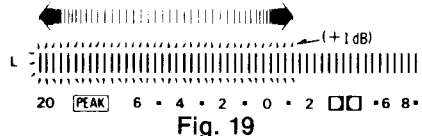
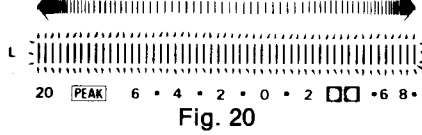
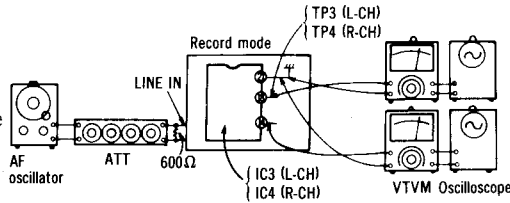
ITEM	MEASUREMENT & ADJUSTMENT
<p>Equipment:</p> <ul style="list-style-type: none"> • VTVM • AF oscillator • ATT • Oscilloscope • Resistor (600Ω) • Test tape (reference blank tape) • ... QZCRA for Normal 	<ol style="list-style-type: none"> 7. If measured value is not 0.45 V, adjust VR5 (L-CH), VR6 (R-CH) (See fig. 1 on). 8. Repeat from step (2).
<p>① Fluorescent meter</p> <p>Condition:</p> <ul style="list-style-type: none"> • Record mode • Tape selector • ... Normal position • Input level controls ... MAX <p>Equipment:</p> <ul style="list-style-type: none"> • VTVM • AF oscillator • ATT 	<ol style="list-style-type: none"> 1. Test equipment connection is shown in fig. 16. 2. As shown in fig. 17, connect the collector of Q8 and peak reset terminal. 3. Supply 1kHz signal (-24 dB) to the LINE IN jack, then press the record button. 4. Adjust the ATT so that the output level at LINE OUT jack becomes 0.45 V (The input level at this condition is termed the standard input level). 5. Adjustment at "-20 dB": <ol style="list-style-type: none"> A. Adjust the ATT so that input level is -20 dB below standard recording level. B. Adjust VR7 so that the -20 dB segment lights up in the -20 ± 1 dB range (L-CH ONLY) (See fig. 18). 6. Adjustment at "0 dB": <ol style="list-style-type: none"> A. Adjust the ATT so that the output level at LINE OUT jack becomes 0.45 V. (The input level at this condition is termed the standard input level.) B. Adjust VR8 so that the +1 dB segment lights up in the 0 ± 0.2 dB range of the standard input level (See fig. 19). 7. Repeat twice between steps 5 and 6 above. 8. Adjust ATT and check that all segments light up when an input signal level is increased to 10 dB higher than the standard input level (See fig. 20). <div style="text-align: right;">  <p>Fig. 17</p> </div> <div style="text-align: right;">  <p>Fig. 18</p> </div> <div style="text-align: right;">  <p>Fig. 19</p> </div> <div style="text-align: right;">  <p>Fig. 20</p> </div>
<p>② Dolby NR circuit</p> <p>Condition:</p> <ul style="list-style-type: none"> • Record mode • Dolby NR switch ... IN/OUT • Dolby NR select switch • ... B/C • Input level controls ... MAX <p>Equipment:</p> <ul style="list-style-type: none"> • VTVM • AF oscillator • ATT • Oscilloscope • Resistor (600Ω) 	<p>Dolby circuit frequency response check</p> <ul style="list-style-type: none"> • Check of the Dolby-B type encoder characteristics <ol style="list-style-type: none"> 1. Make connections as shown in fig. 21. 2. Set the unit to the record mode. (NR select switch is OUT.) 3. Apply a 1 kHz signal to LINE IN. 4. Adjust the ATT so that the output level at TP3 (L-CH) and TP4 (R-CH) is 12.3 mV. 5. The output level at pin 14 should be 0 dB. 6. Set the NR select switch to B, and make sure that the output signal level at pin 14 of IC3 (L-CH) and IC4 (R-CH) is $+6 \text{ dB} \pm 2.5 \text{ dB}$. 7. Set the NR select switch to OUT, and adjust the frequency to 5 kHz. The output signal level at pin 14 should be 0 dB. 8. Set the NR select switch to B and make sure that the output signal level at pin 14 of IC3 (L-CH) and IC4 (R-CH) is $8 \text{ dB} \pm 2.5 \text{ dB}$. • Check of Dolby-C type encoder characteristics <ol style="list-style-type: none"> 9. Repeat steps 1-5 above. 10. Set the NR select switch to C and make sure that the output signal level at pin 14 of IC3 (L-CH) and IC4 (R-CH) is $11.5 \text{ dB} \pm 2.5 \text{ dB}$. 11. Set the NR select switch to OUT and adjust the frequency to 5 kHz. The output signal at pin 14 should be 0 dB. 12. Set the NR select switch to C and make sure that the output signal level at pin 14 of IC3 (L-CH) and IC4 (R-CH) is $8.5 \text{ dB} \pm 2.5 \text{ dB}$. <div style="text-align: right;">  <p>Fig. 21</p> </div>

ELECTRICAL PARTS LOCATION

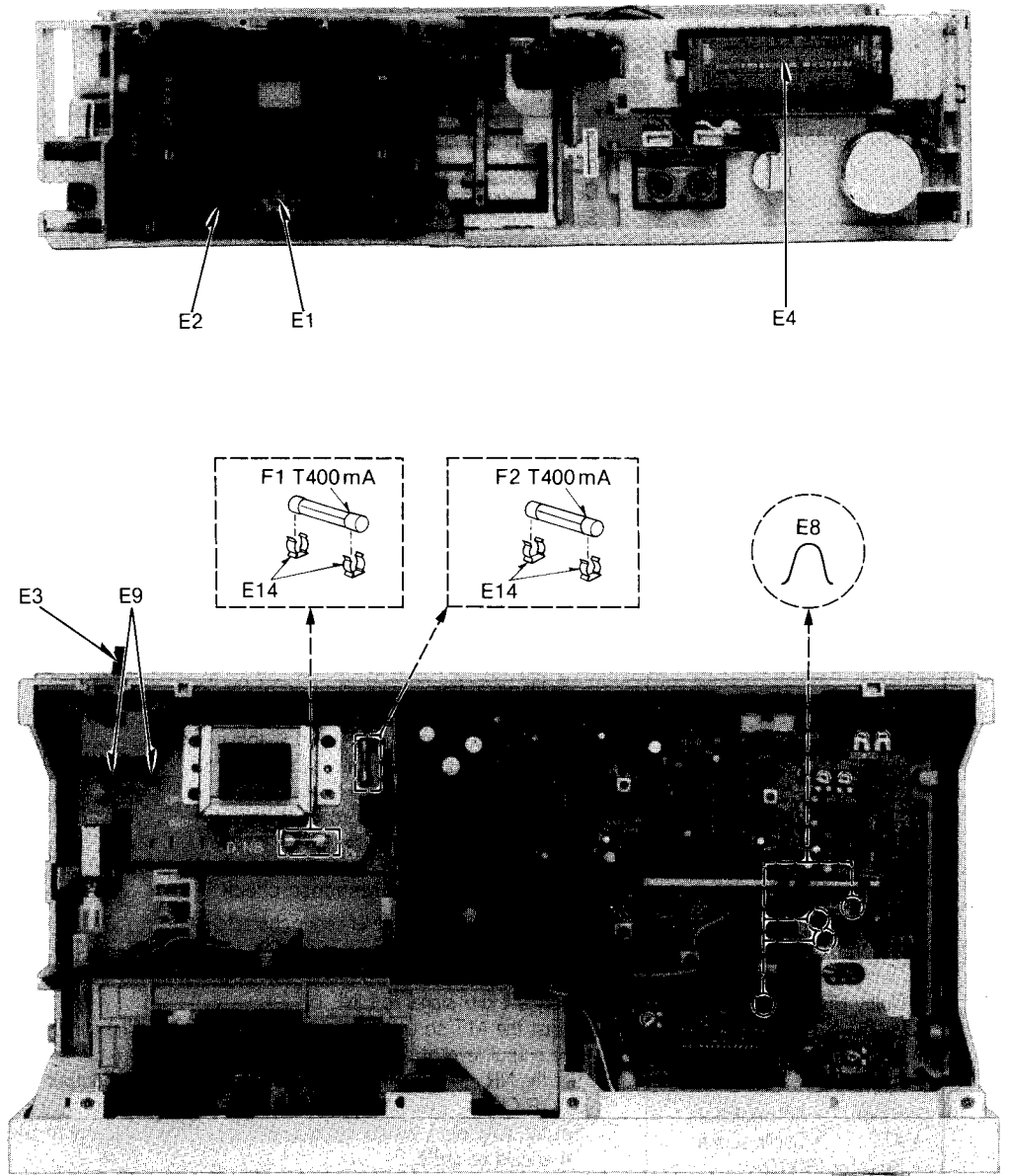
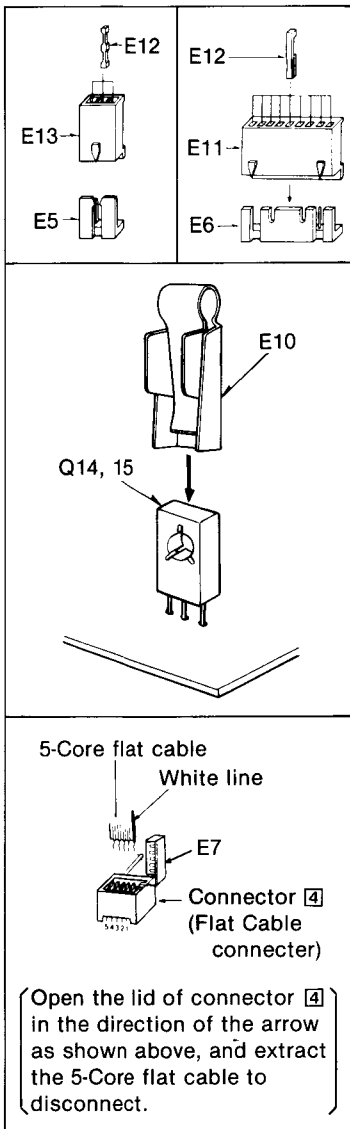

REPLACEMENT PARTS LIST

Important safety notice
Components identified by Δ mark have special characteristics important for safety.
When replacing any of these components, use only manufacturer's specified parts.

Ref No.	Part No.	Part Name & Description	Ref No.	Part No.	Part Name & Description
ELECTRICAL PARTS					
E 1	QWY4122Z	Record/Playback Head	E 7	QJS1961S	Flat Cable Connector
E 2	QWY2138Z	Erase Head	E 8	QJT1090	Pin Terminal-A (Test Point)
E 3	[D] Δ RJA23ZC	AC Power Cord [For all European areas except United Kingdom.]	E 9	SJT777	Pin Terminal-B (AC Power Cord)
	[B] Δ QFC1205M	AC Power Cord [For United Kingdom.]	E 10	NO39	Heat Sink
E 4	QSiFL006F	FL Meter	E 11	QJS1923TN	9 Pin Socket
E 5	QJP1921TN	3 Pin Post	E 12	QJT1054	Contact
E 6	QJP1923TN	9 Pin Post	E 13	QJS1921TN	3 Pin Socket
			E 14	Δ QTF1054	Fuse Holder

BLOCK DIAGRAM

Recording System (L-CH ONLY)

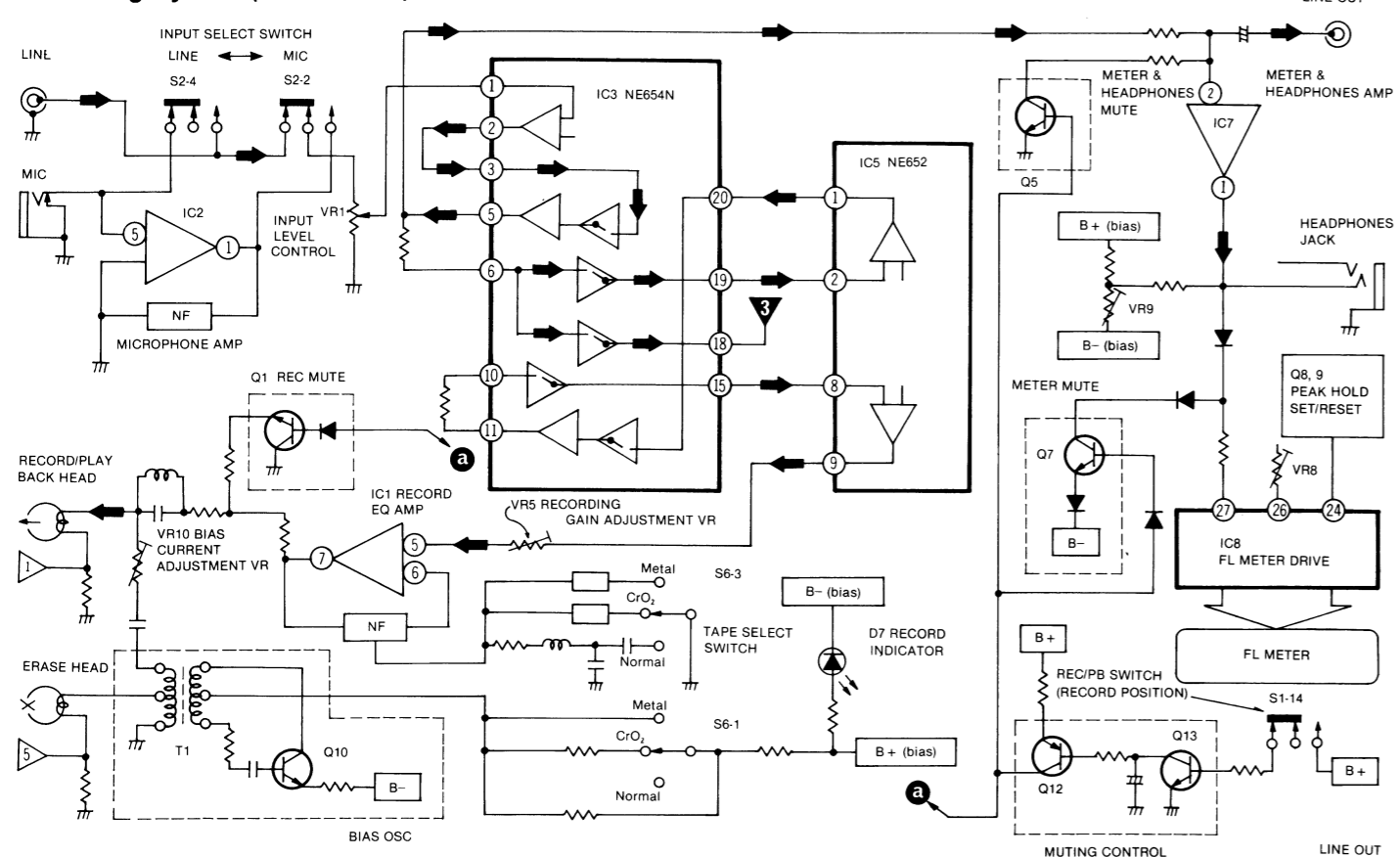

Playback System (L-CH ONLY)

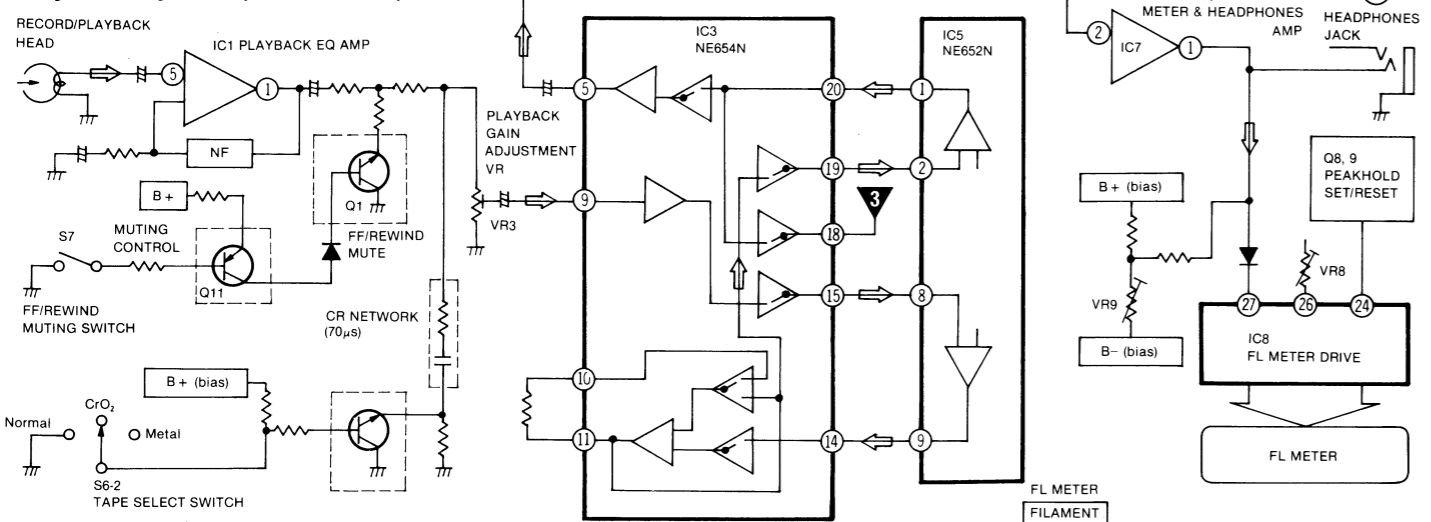

Power Supply System

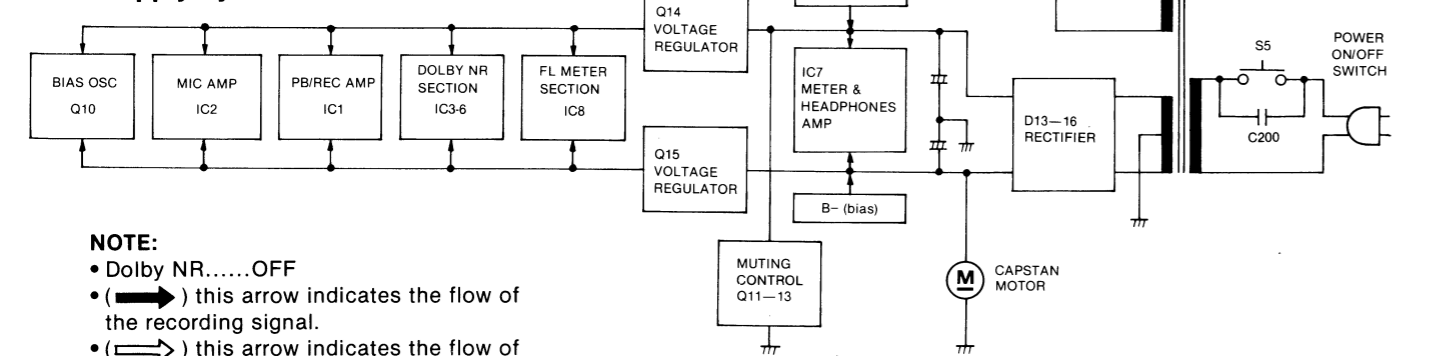

NOTE:
 • Dolby NR.....OFF
 • (→) this arrow indicates the flow of the recording signal.
 • (⇌) this arrow indicates the flow of the playback signal.

DOLBY SYSTEM (L-CH ONLY)

Dolby-B Encode

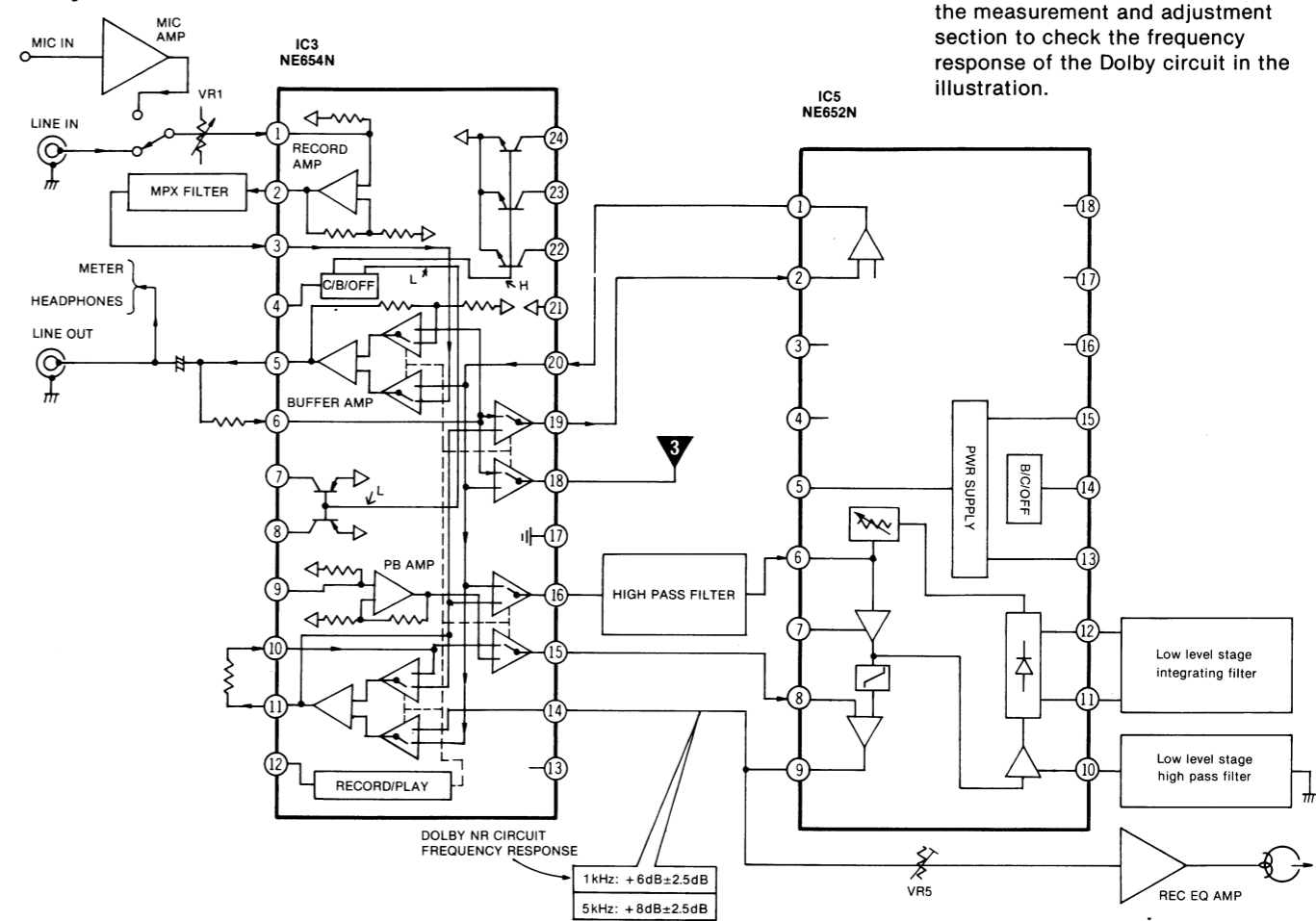

Refer to Item ③ "Dolby NR circuit" of the measurement and adjustment section to check the frequency response of the Dolby circuit in the illustration.

Dolby-B Decode

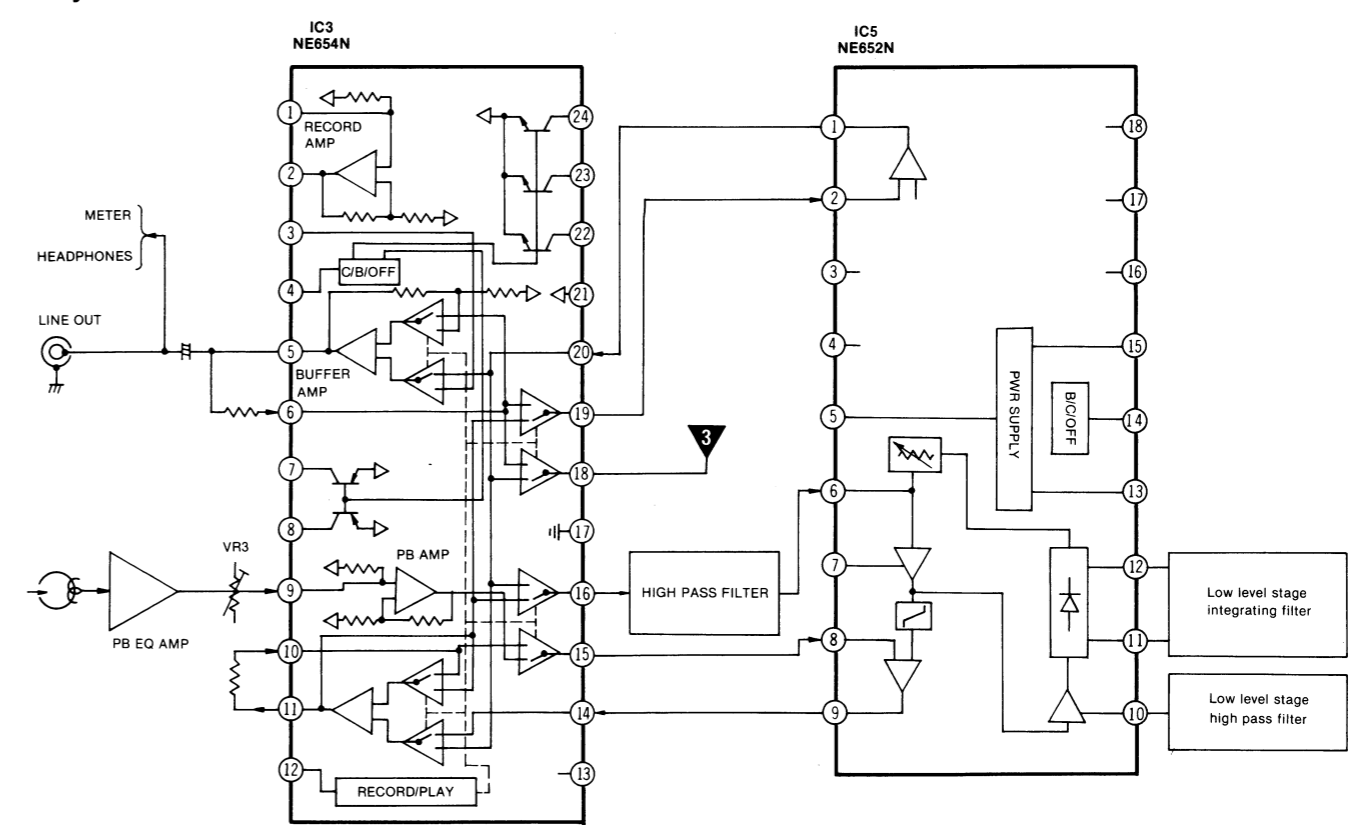

Dolby-C Encode

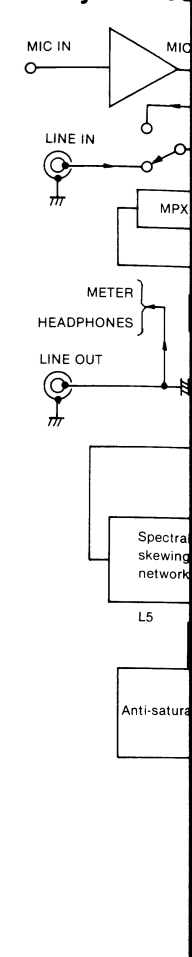

Dolby-C Decode

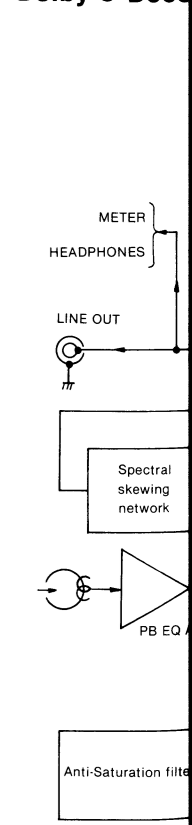

DOLBY SYSTEM (L-CH ONLY)

Dolby-B Encode

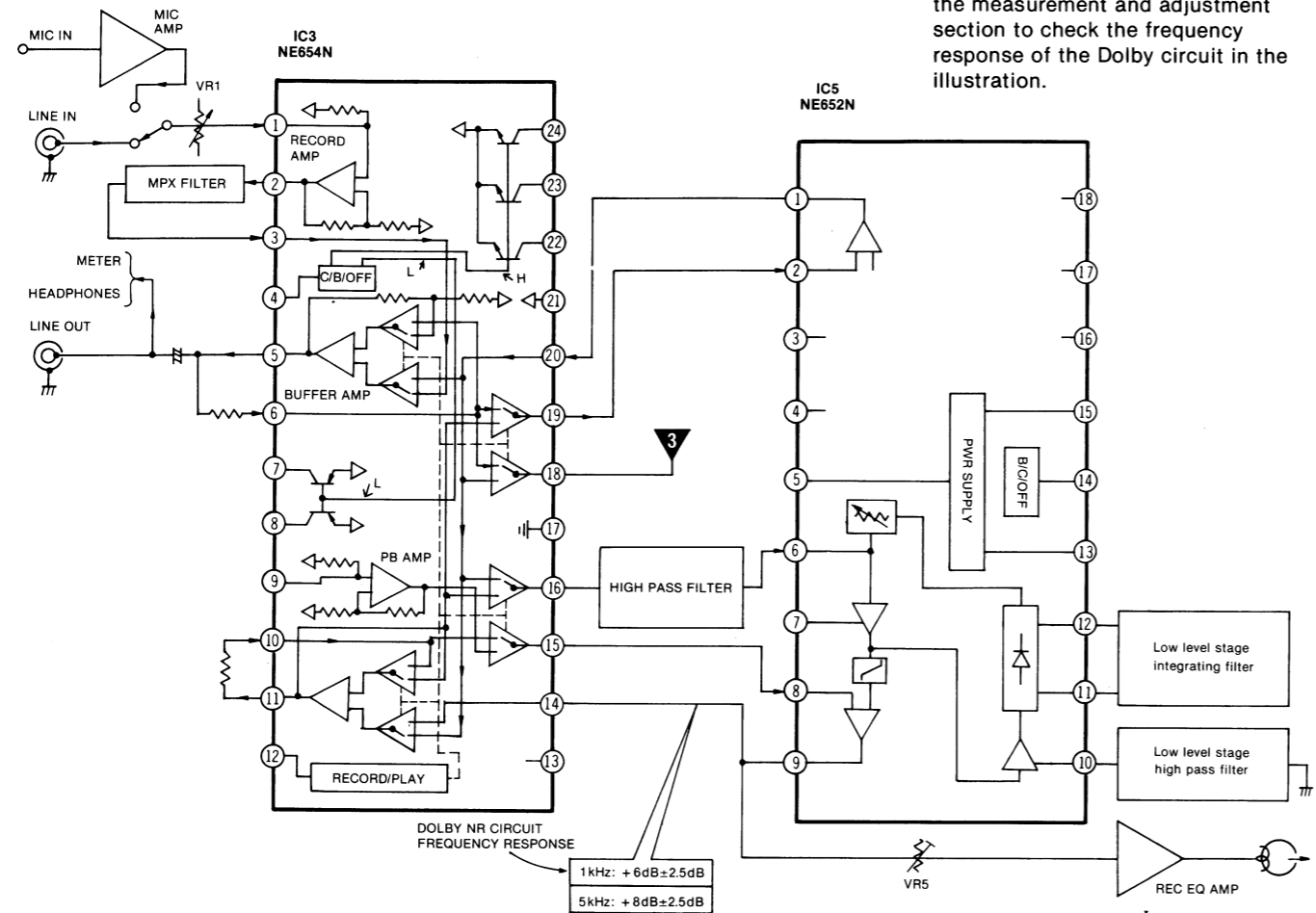

Refer to Item 3 "Dolby NR circuit" of the measurement and adjustment section to check the frequency response of the Dolby circuit in the illustration.

Dolby-C Encode

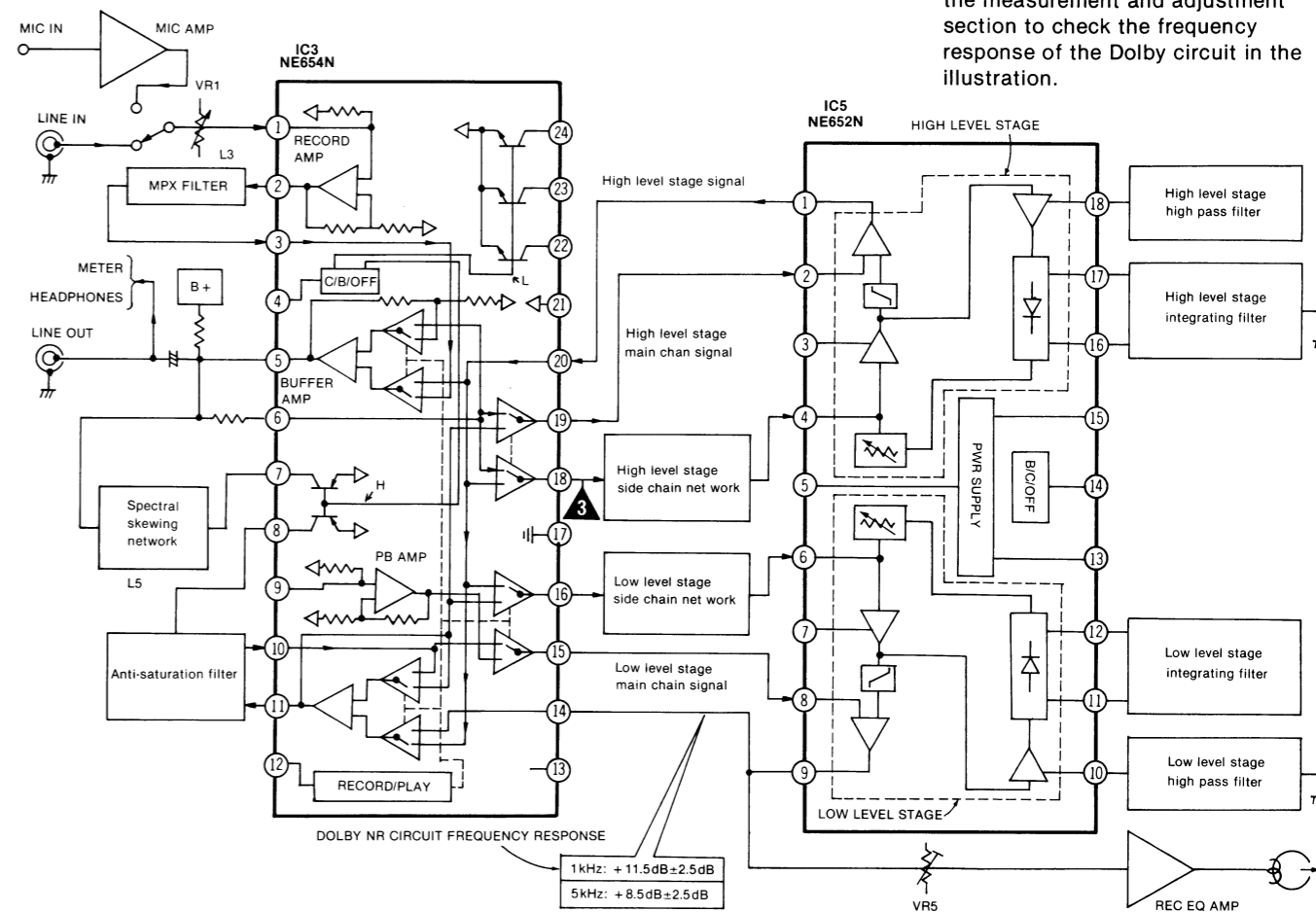

Refer to Item 3 "Dolby NR circuit" of the measurement and adjustment section to check the frequency response of the Dolby circuit in the illustration.

Dolby-B Decode

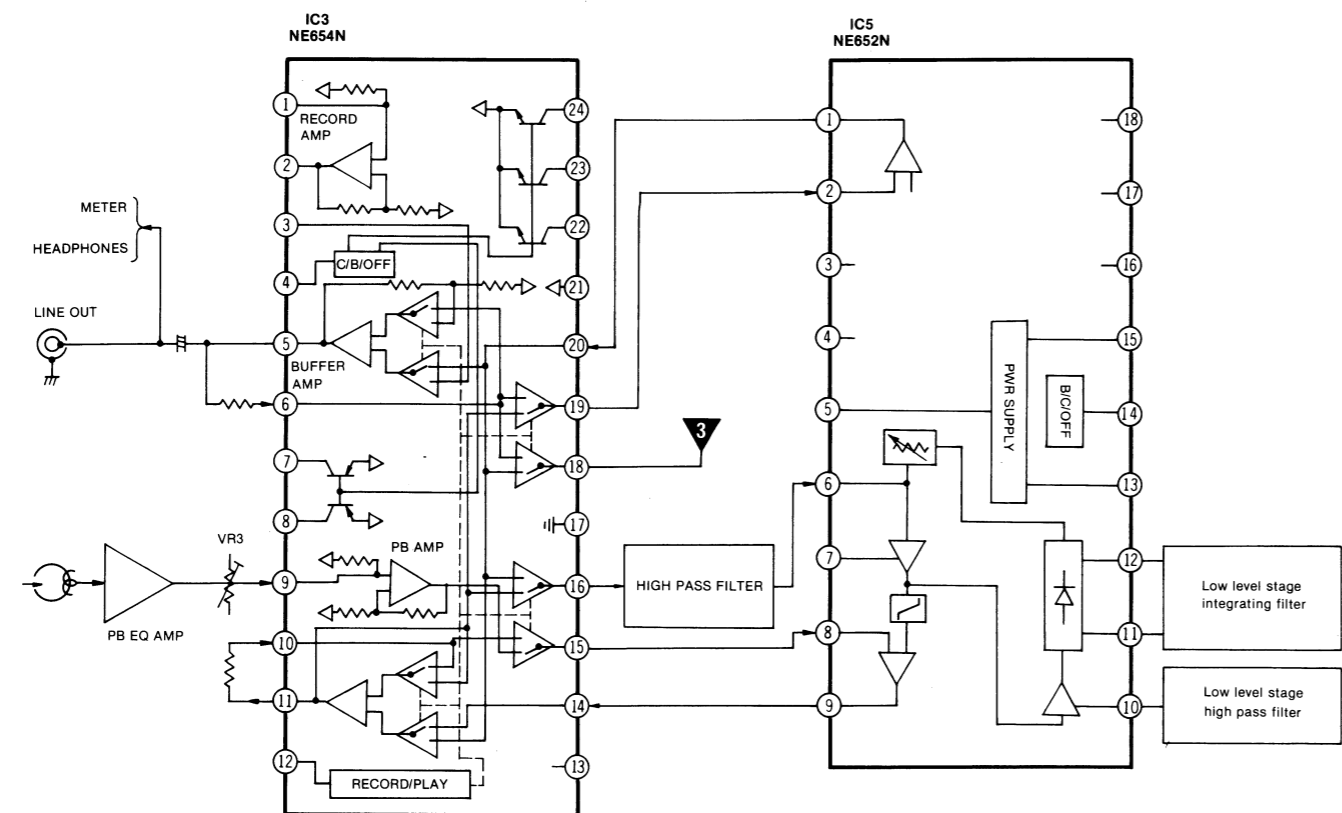

Dolby-C Decode

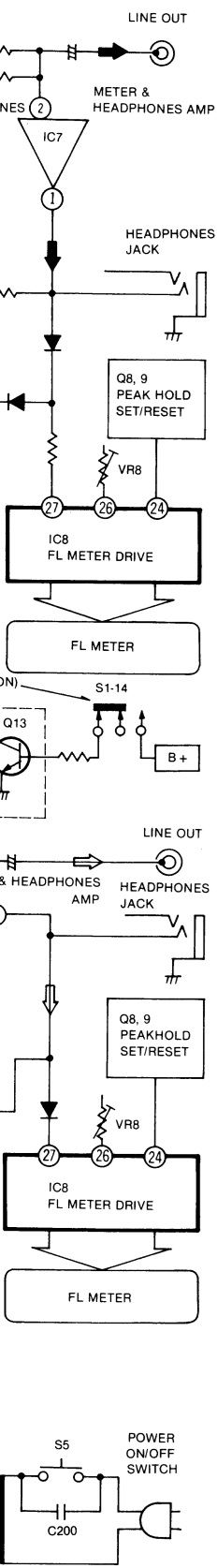
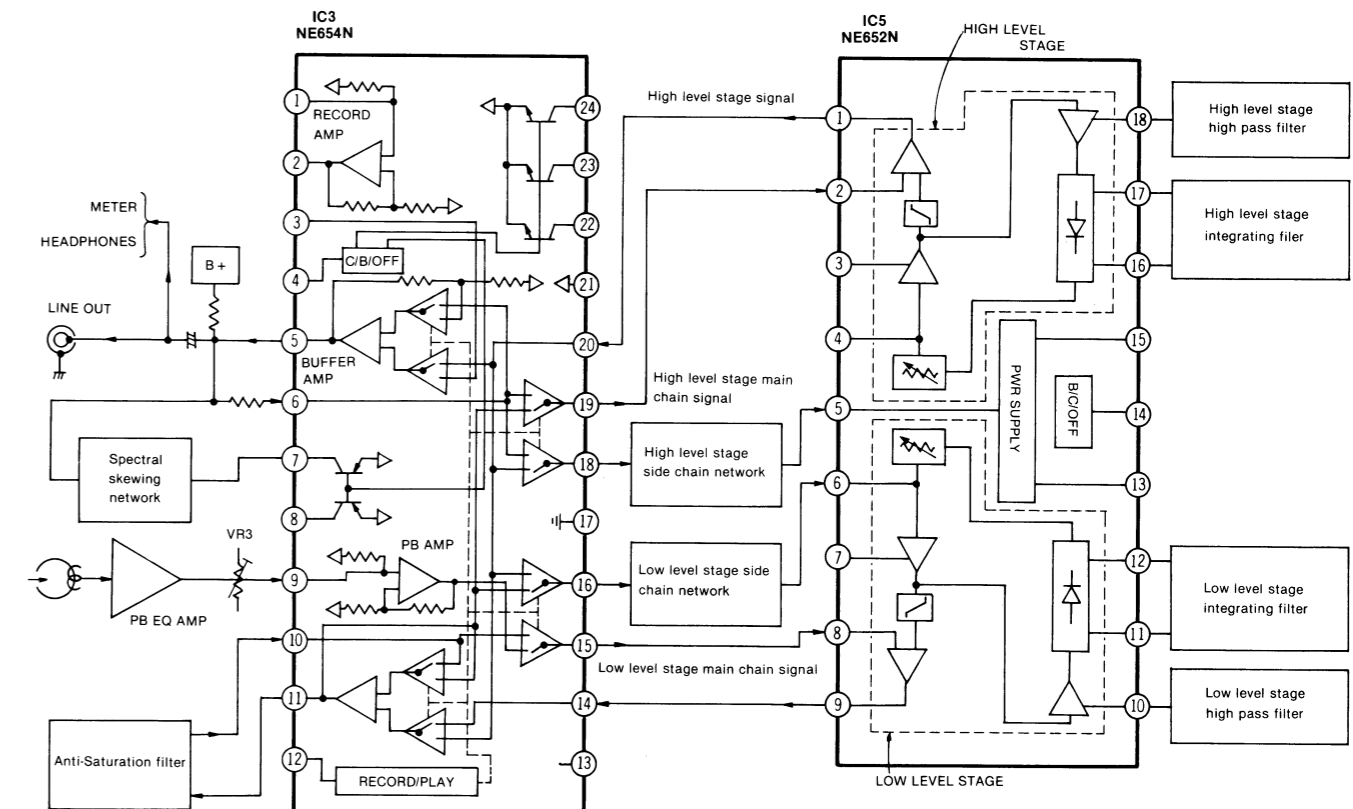

- NOTES: RESISTORS**
 ERDCarbon
 ERGMetal-oxide
 ERSMetal-oxide
 EROMetal-film
 ERXMetal-film
 ERQFuse type metallic
 ERCSolid
 ERFCement
- CAPACITORS**
 ECBACeramic
 ECGCeramic
 ECKCeramic
 ECCCeramic
 ECFCeramic
 ECQMPolyester film
 ECQEPolyester film
 ECQPPolypropylene
- Electrolytic**
 ECEElectrolytic
 ECENNon polar electrolytic
 ECOSPolystyrene
 ECSTantalum
 QCSTantalum

REPLACEMENT PARTS LIST

Important safety notice
 Components identified by Δ mark have special characteristics important for safety.
 When replacing any of these components, use only manufacturer's specified parts.

Ref No.	Part No.	Ref No.	Part No.	Ref No.	Part No.	Ref No.	Part No.
RESISTORS							
R 1, 2	ERD25FJ100	R 132	ERD25FJ681	C 85, 86	ECQV05154JZ	Z 3	(R 93 and C 93)
R 3, 4	ERD25FJ101	R 133	ERD25FJ561	C 87, 88	ECKD1H103ZF		EXRP220K124T
R 5, 6	ERD25TJ104	R 134, 135	ERD25FJ101	C 89, 90	ECQM1H104JZ	Z 4	(R 94 and C 94)
R 7, 8	ERD25FJ102	R 136	ERD25FJ102	C 91, 92	ECQM1H333JZ		EXRP220K124T
R 9, 10	ERD25FJ680	R 137	ERD25FJ152	C 93 (22PF)	refer to Z 3	TRANSISTORS	
R 11, 12	ERD25TJ184	R 138	ERD25TJ123	C 94 (22PF)	refer to Z 4	Q 1, 2, 3, 4, 5, 6, 7	2SD636
R 13, 14	ERD25FJ682	R 139	ERD25TJ153	C 95, 96	ECEA1HS100	Q 8	2SB641
R 15, 16	ERD25FJ103	R 140	ERD25TJ473	C 97, 98	ECKD1H103ZF	Q 9	2SD636
R 17, 18	ERD25FJ680	R 141	ERD25FJ390	C 99, 100, 101, 102		Q 10	2SD592
R 19, 20	ERD25FJ392					Q 11	2SB641
		R 142, 143	ERD25TJ473			Q 12	2SD636
		R 144	ERD25FJ222			Q 13	2SB641
		R 145	ERD25FJ103			Q 14	2SC1846R
		R 146	ERD25TJ333			Q 15	2SA885Q
		R 147	ERD25FJ561			DIODES & RECTIFIERS	
		R 148	ERD25TJ153	C 103	ECEA1HS100	D 1, 2, 3, 4, 5, 6	MA161
		R 149	ERD25TJ473	C 104	ECFDD473MXY	D 7	LN216RP
		R 150, 151	ERD25FJ681	C 105, 106	ECCD1H101K	D 8, 9, 10, 11	MA161
		R 152	ERD25FJ103	C 107	ECQP1183JZ	D 12	MA1220M
		R 153, 154	ERD25TJ334	C 108	ECQM1H153JZ	D 13, 14, 15, 16	SM112
				C 109	ECQM1H822JZ	D 17, 18	MA161
				C 110	ECEA502R2	D 21	MA1047
				C 111	ECEA25Z4R7	INTEGRATED CIRCUITS	
				C 112	ECEA1CS221	IC 1, 2	M5219L
				C 113, 114	ECEA1CS331	IC 3, 4	NE654N
				C 115, 116		IC 5, 6	NE652N
						IC 7	M5218L
						IC 8	AN6870N
						COMBINATION PARTS	
						Z 1	(R 33 and C 13)
							EXRP220K124T
						Z 2	(R 34 and C 14)
							EXRP220K124T
						VARIABLE RESISTORS	
						VR 1, 2	EWJS3AF22A54
						VR 3, 4	EVNM4AA00B24
						VR 5, 6	EVNM4AA00B23
						VR 7	EVNM4AA00B24
						VR 8	EVNM4AA00B14
						VR 9, 10	EVNM4AA00B25
						CAPACITORS	
R 63, 64	ERD25FJ512	C 3, 4	ECKD1H681KB			COILS	
R 65, 66	ERD25TJ683	C 5	ECKD1H102KB	L 1, 2	QLQX2721D	Peaking Coil	
R 67, 68	ERD25FJ222	C 6	ECBS1H102KBY	L 3, 4	QLM929K	MPX Coil	
R 69, 70	ERD25FJ472	C 9	ECEA25Z4R7	L 5, 6	ELM7Q306A	Combination Coil	
R 71, 72	ERD25TJ123	C 11, 12	ECKD1H102KB	L 7, 8	QLQX0343KWA	Bias Trap Coil	
R 73, 74	ERD25TJ473	C 13 (22PF)	refer to Z 1	TRANSFORMERS			
R 75, 76	ERD25TJ753	C 14 (22PF)	refer to Z 2	T 1	QLB0198	Bias Oscillation Coil	
R 77, 78, 79, 80	ERD25TJ394	C 15, 16	ECKD1H681KB	T 2	[D] Δ QLPD68EK	AC Power Transformer	
R 81, 82	ERD25TJ334	C 17, 18	ECQM1H183JZ		[B] Δ QLPA65EK	AC Power Transformer	
R 83, 84	ERD25FJ821	C 19, 20	ECEA1AS101		[For all European areas except United Kingdom.]		
					[For United Kingdom.]		
						FUSES	
R 85, 86	ERG1ANJ470	C 21, 22	ECKD2H121KB	F 1, 2	XBAQ0007	Fuse (T 400mA)	
R 87, 88	ERD25TJ333	C 23, 24	ECQM1H273JZ			SWITCHES	
R 89, 90	ERD25TJ273	C 25, 26	ECQM1H153JZ	S 1	QSSE203	Record/Playback Select Switch	
R 91, 92	ERD25FJ332	C 27, 28	ECFDD273KXY	S 2, 3 and 4	QSWX312	Combination Switch (Input Select/Dolby SW/Dolby B-C Selector)	
R 93 (120K Ω)	refer to Z 3	C 29, 30	ECFDD223KXY	S 5	ESB822S	Push Switch (Power ON/OFF)	
R 94 (120K Ω)	refer to Z 4	C 31, 32	ECEA50Z4R7	S 6	QSR4306	Rotary Switch (Tape Select Switch)	
R 95, 96	ERD25FJ152	C 33, 34	ECEA50Z1	S 7	QSB0251	FF/Rewind Muting Switch	
R 97, 98	ERD25TJ224	C 35, 36	ECEA25Z4R7	S 8	QSB0251	Playback Switch	
R 99, 100	ERD25FJ151	C 37, 38	ECKD1H103ZF			JACKS	
R 101	ERD25FJ332	C 39, 40	ECQM1H123JZ	J 1, 2	QJA0451	Microphone Jack	
				J 3	QJA0259	Headphones Jack	
				J 4, 5, 6, 7	QEJ5028S	Jack Board (Line IN/OUT)	

SCHEMATIC DIAGRAM

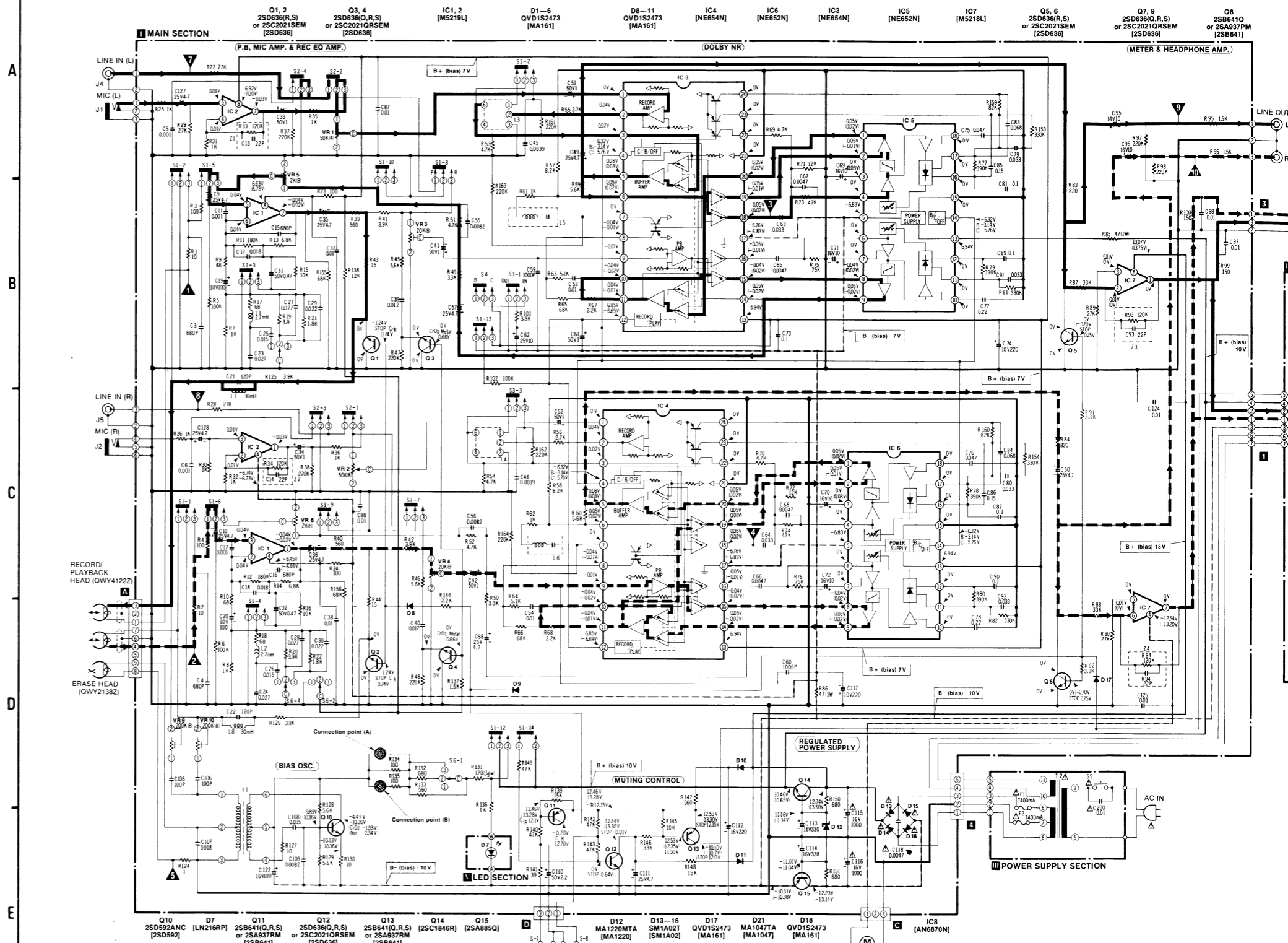

NOTES:

- S1-1—S1-14.....Record/playback select switch (shown in playback position).
- S2-1—S2-4.....Input select switch (shown in LINE IN position).
- S3-1—S3-3.....Dolby NR/MPX filter IN/OUT select switch (shown in NR IN/MPX IN position).
- S4.....Dolby NR (B/C) select switch (shown in Dolby B position).
- S5.....Power ON/OFF switch.
- S6-1—S6-4.....Tape select switch (shown in CrO₂ position).
 (1).....Normal, (2).....CrO₂, (3).....Metal.
- S7.....FF/Rewind muting switch (shown in OFF position).
- S8.....Playback switch (shown in OFF position).
- VR1, 2.....Input level controls.
- VR3, 4.....Playback gain adjustment VR.
- VR5, 6.....Recording gain adjustment VR.
- VR7.....FL meter adjustment VR (for -20dB indication).
- VR8.....FL meter adjustment VR (for 0dB indication).
- VR9, 10.....Bias current adjustment VR.
- Connection points (A) and (B).....For erase current adjustment.
- Resistance are in ohms (Ω), 1/4 watt unless specified otherwise.
 K = 1,000 Ω , M = 1,000K Ω .
- Capacity are in microfarads (μ F) unless specified otherwise.
 P = Pico-farads.
- The mark (∇) shows test point. e.g. ∇ = Test point 1.
- (\blacktriangle) this arrow indicates the flow of the playback signal.
- (\blacktriangleright) this arrow indicates the flow of the recording signal.
- Important safety notice
 Components identified by Δ mark have special characteristics important for safety. When replacing any of these components, use only manufacturer's specified parts.

CHEMATIC DIAGRAM

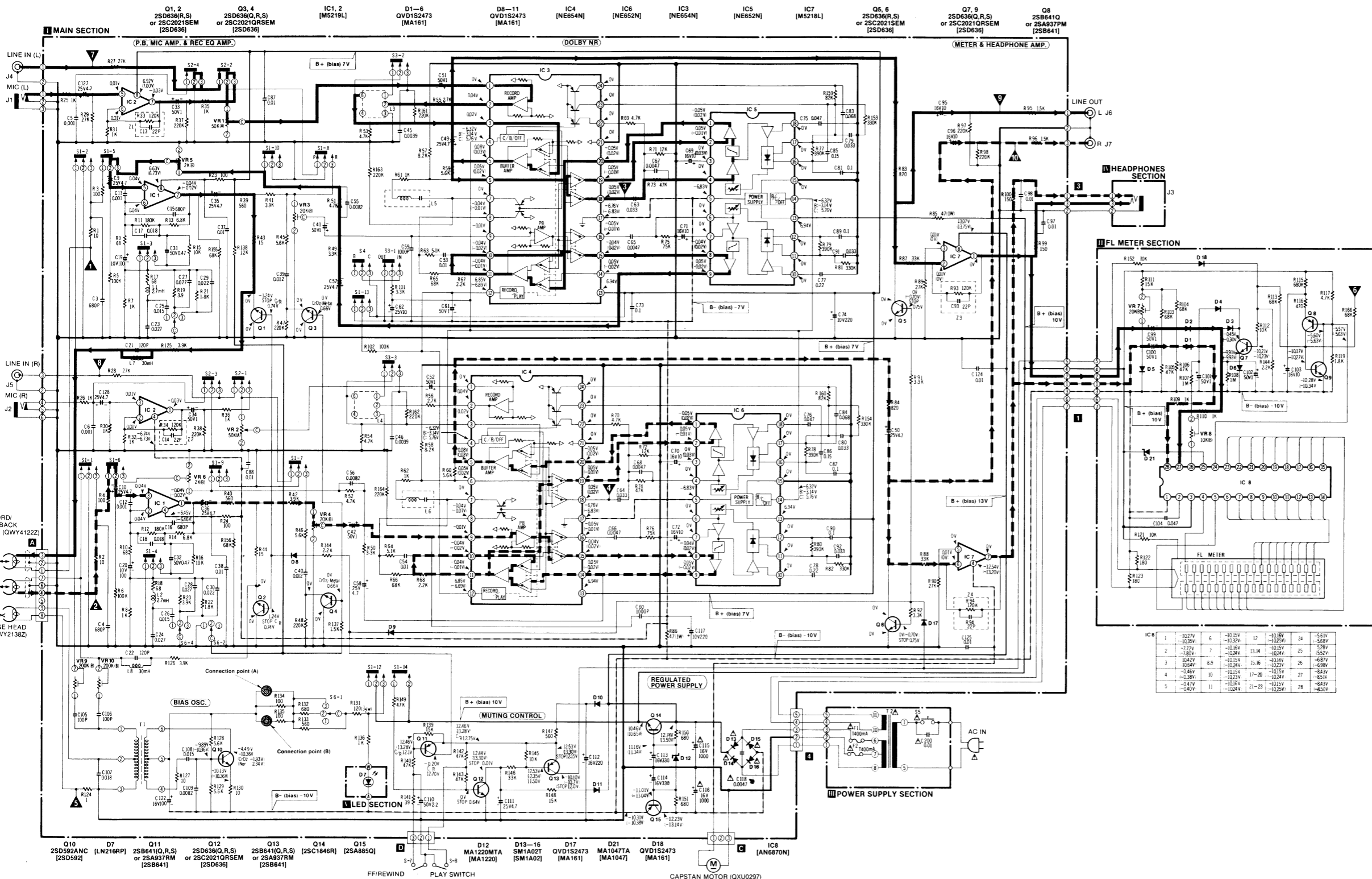

EQUIVALENT CIRCUIT

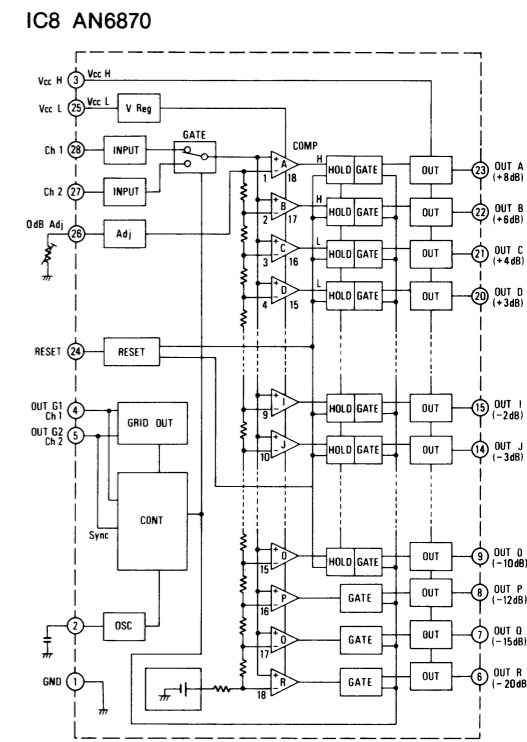
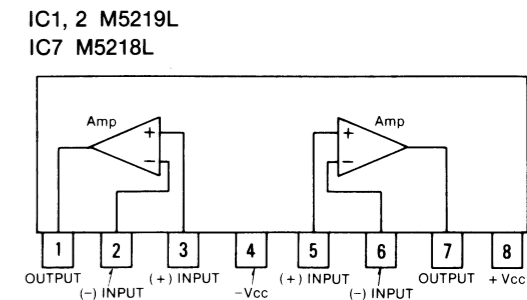

SPECIFICATIONS • Input level controls...MAX

Playback S/N ratio Test tape ... QZZCFM	Greater than 45 dB (without NAB filter)
Overall distortion Test tape ... QZZCRA for Normal ... QZZCRX for CrO ₂ ... QZZCRZ for Metal	Less than 4%
Overall S/N ratio Test tape ... QZZCRA	Greater than 43 dB

- NOTES:**
- S1-1—S1-14.....Record/playback select switch (shown in playback position).
 - S2-1—S2-4Input select switch (shown in LINE IN position).
 - S3-1—S3-3Dolby NR/MPX filter IN/OUT select switch (shown in NR IN MPX IN position).
 - S4Dolby NR (B/C) select switch (shown in Dolby B position).
 - S5Power ON/OFF switch.
 - S6-1—S6-4Tape select switch (shown in CrO₂ position).
(1)...Normal, (2)...CrO₂, (3)...Metal.
 - S7FF/Rewind muting switch (shown in OFF position).
 - S8Playback switch (shown in OFF position).
 - VR1, 2Input level controls.
 - VR3, 4Playback gain adjustment VR.
 - VR5, 6Recording gain adjustment VR.

- VR7FL meter adjustment VR (for -20dB indication).
- VR8FL meter adjustment VR (for 0dB indication).
- VR9, 10Bias current adjustment VR.
- Connection points (A) and (B)...For erase current adjustment.
- Resistance are in ohms (Ω), 1/4 watt unless specified otherwise.
- Capacity are in microfarads (μF) unless specified otherwise.
- P = Pico-farads.
- The mark (▼) shows test point. e.g. ▼ = Test point 1.
- (▶) this arrow indicates the flow of the playback signal.
- (▶) this arrow indicates the flow of the recording signal.
- Important safety notice
Components identified by Δ mark have special characteristics important for safety. When replacing any of these components, use only manufacturer's specified parts.

- All voltage values shown in circuitry are under no signal condition. Unless otherwise specified, voltage measurement conditions are that tape travels is at STOP, tape mode at NORMAL, and Dolby NR switch at OFF.
- RECVoltage at record mode.
- PLAYVoltage at playback mode.
- REC/PLAYVoltage at record/playback mode.
- NormalVoltage at Normal tape mode.
- CrO₂Voltage at CrO₂ tape mode.
- MetalVoltage at Metal tape mode.
- STOPVoltage at STOP mode.
- C/RVoltage at Cue/Review mode.
- BVoltage at Dolby-B mode.
- CVoltage at Dolby-C mode.

- Described in the schematic diagram are two types of numbers; the supply parts number and production parts number for transistors and diodes. One type of number is used for supply parts number and production parts number when they are identical.
e.g. Q1
{2SB745(TMG, UMG)} ← Production parts number
{2SB745T} ← Supply parts number
- The supply parts number is described alone in the replacement parts list.
- This schematic diagram may be modified at any time with the development of new technology.

CIRCUIT BOARDS AND WIRING CONNECTION DIAGRAM

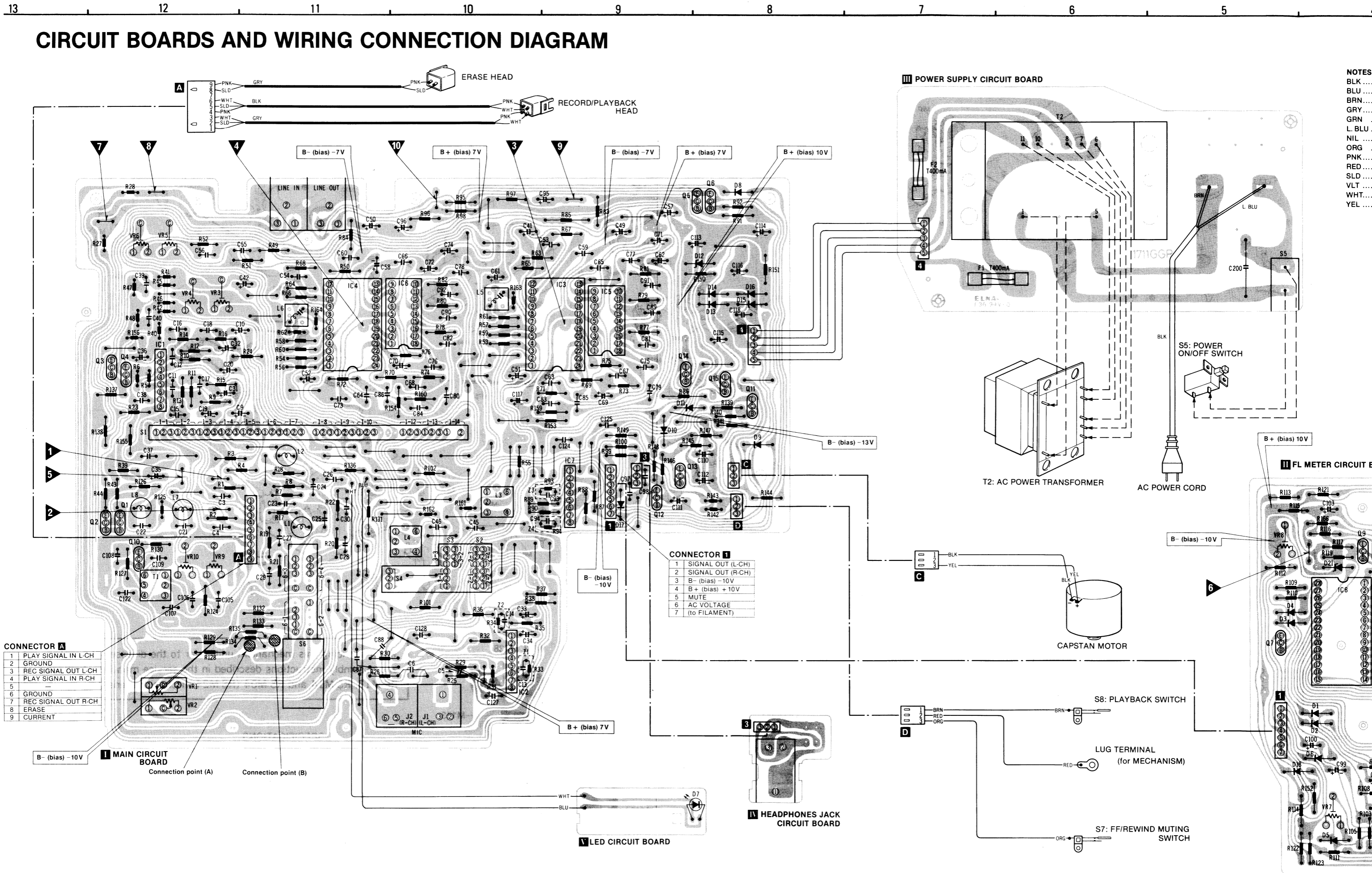

CONNECTOR A

1	PLAY SIGNAL IN L-CH
2	GROUND
3	REC SIGNAL OUT L-CH
4	PLAY SIGNAL IN R-CH
5	---
6	GROUND
7	REC SIGNAL OUT R-CH
8	ERASE
9	CURRENT

CONNECTOR 1

1	SIGNAL OUT (L-CH)
2	SIGNAL OUT (R-CH)
3	B- (bias) -10V
4	B+ (bias) +10V
5	MUTE
7	AC VOLTAGE (to FILAMENT)

- NOTES:**
- BLKBlack
 - BLUBlue
 - BRNBrown
 - GRYGray
 - GRNGreen
 - L. BLULight Blue
 - NILNo Color
 - ORGOrange
 - PNKPink
 - REDRed
 - SLDShield
 - VLTViolet
 - WHTWhite
 - YELYellow

DIAGRAM

RECORD/PLAYBACK HEAD

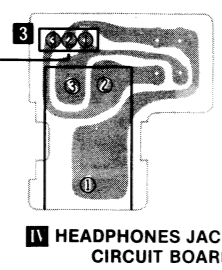
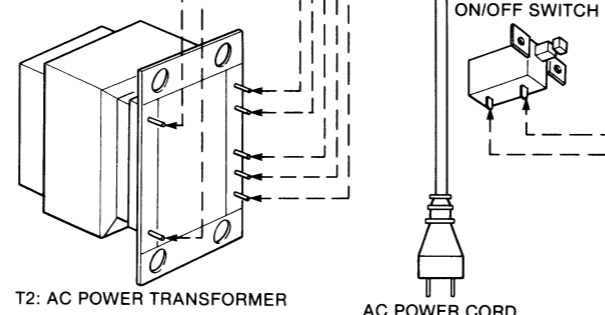
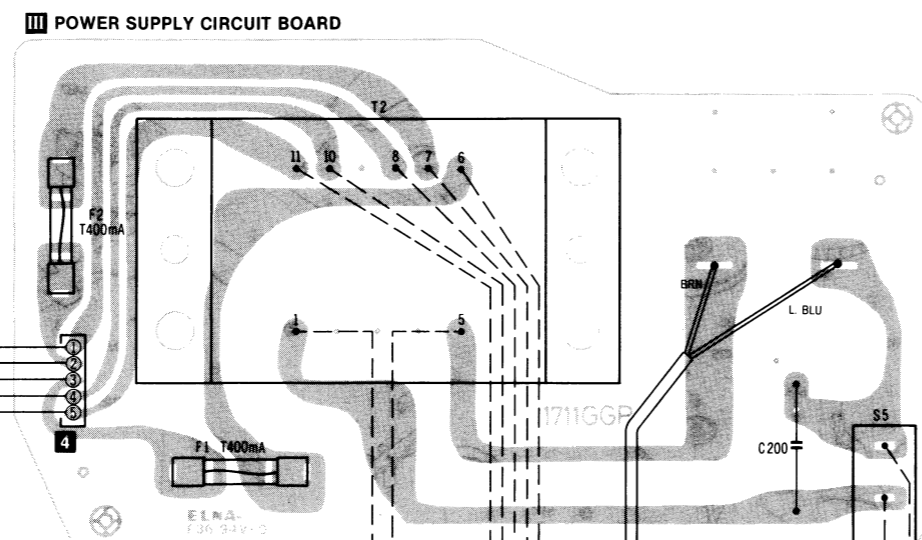
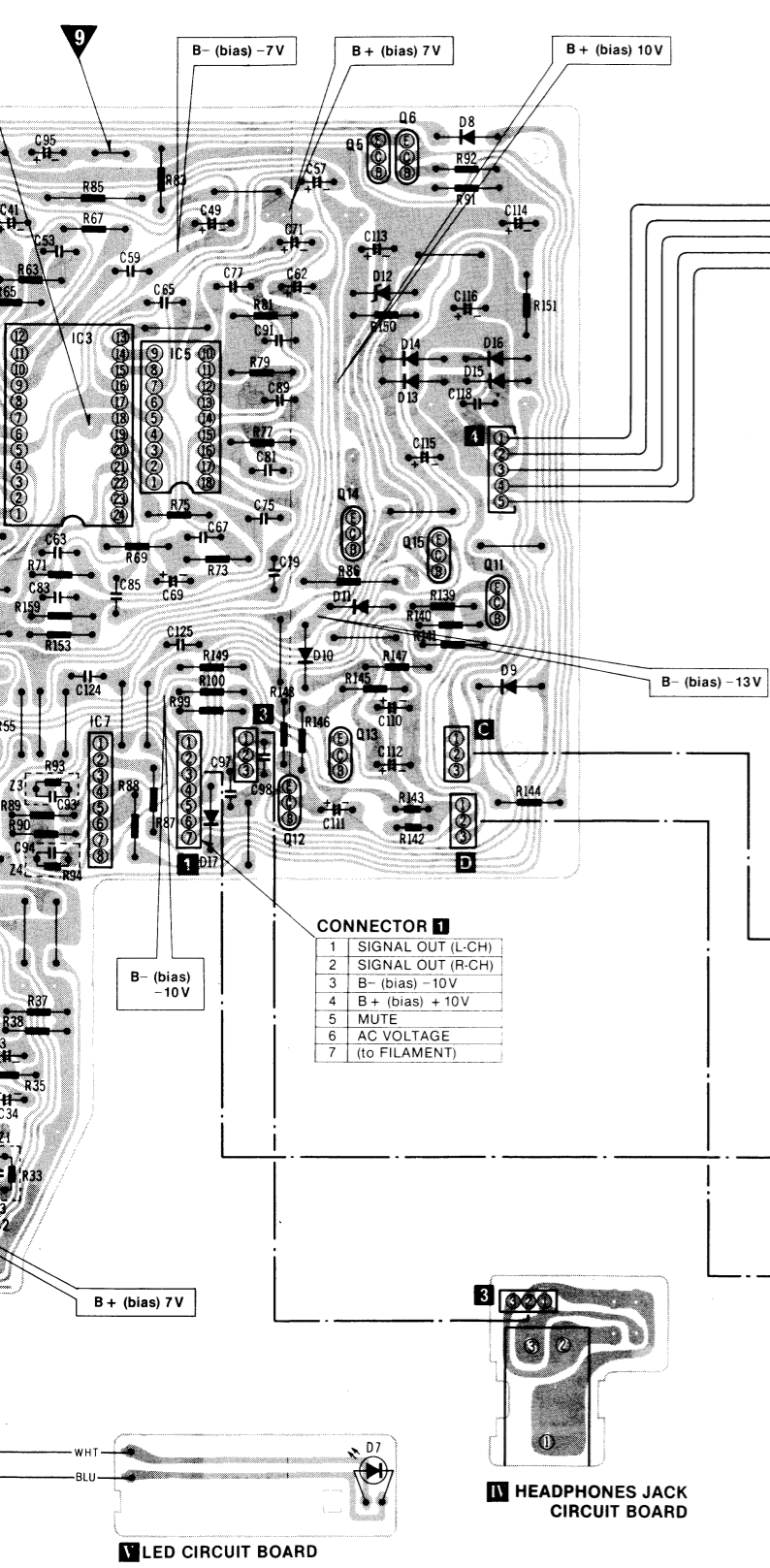

NOTES:
 BLKBlack
 BLUBlue
 BRNBrown
 GRNGray
 L.BLU ...Light Blue
 NILNo Color Mark
 ORGOrange
 REDRed
 SLDShield Wire
 VLTViolet
 WHT.....White
 YELYellow

IC1 [M5219L]		IC2 [M5219L]		Q1, 2 [2SD636]	
1	-0.04V (-0.02V)	1	-0.03V (-0.03V)	B	-1.24V (-1.24V) STOP C/R 0.74V
2	0.04V (0.04V)	2	0.01V (0.01V)	C	0V (0V) 0V
3	0.04V (0.04V)	3	0.01V (0.01V)	E	0V (0V) 0V
4	-6.45V (-6.46V)	4	-6.74V (-6.73V)		
5	0.04V (0.04V)	5	0.01V (0.01V)		
6	0.04V (0.04V)	6	0.01V (0.01V)		
7	-0.04V (-0.02V)	7	-0.03V (-0.03V)		
8	6.63V (6.73V)	8	6.92V (7.00V)		

IC3, 4 [NE654N]		Q3, 4 [2SD636]	
1	0V (0V)	13	6.94V (6.94V)
2	0.04V (0.04V)	14	0.05V (-0.02V)
3	0.02V (0.02V)	15	-0.04V (0.02V)
4	-6.32V (-6.32V)	16	-0.05V (-0.01V)
5	0.08V (0.03V)	17	-6.76V (-6.83V)
6	0.05V (0.02V)	18	0.05V (0.02V)
7	0V (0V)	19	0.05V (-0.01V)
8	-0.04V (-0.01V)	20	-0.05V (0.02V)
9	-0.01V (-0.01V)	21	0V (0V)
10	-0.04V (-0.02V)	22	0V (0V)
11	-0.04V (-0.01V)	23	0V (0V)
12	6.85V (-6.69V)	24	0V (0V)

IC5, 6 [NE652N]		Q5, 6 [2SD636]	
1	-0.05V (0.02V)	10	0V (0V)
2	0.05V (-0.01V)	11	0V (0V)
3	0V (0.03V)	12	0V (0V)
4	0V (0V)	13	6.94V (6.94V)
5	-6.83V (-6.83V)	14	-6.32V (-6.32V) B: -3.14V C: 5.76V
6	0V (0V)	15	0V (0V)
7	0V (0V)	16	0V (0V)
8	-0.04V (0.02V)	17	0V (0V)
9	0.05V (-0.02V)	18	0V (0V)

IC7 [M5218L]		Q7 [2SD636]	
1	0V (0V)	B	-10.21V (-10.23V)
2	0.01V (0V)	C	-0.45V (-0.30V)
3	0.01V (0V)	E	-9.91V (-9.93V)
4	-12.54V (-13.20V)		
5	0V (0V)		
6	0.01V (0V)		
7	0V (0V)		
8	13.07V (13.75V)		

IC8 [AN6870N]		Q8 [2SB641]	
1	-10.27V (-10.35V)	15	-10.14V (-10.23V)
2	-7.72V (-7.80V)	16	-10.14V (-10.23V)
3	10.42V (10.64V)	17	-10.15V (-10.24V)
4	-0.46V (-0.38V)	18	-10.15V (-10.24V)
5	-0.47V (-0.40V)	19	-10.15V (-10.24V)
6	-10.15V (-10.32V)	20	-10.15V (-10.24V)
7	-10.16V (-10.24V)	21	-10.15V (-10.25V)
8	-10.15V (-10.24V)	22	-10.15V (-10.25V)
9	-10.15V (-10.24V)	23	-10.15V (-10.25V)
10	-10.15V (-10.23V)	24	-5.61V (-5.68V)
11	-10.16V (-10.24V)	25	5.28V (5.52V)
12	-10.16V (-10.25V)	26	-6.87V (-6.98V)
13	-10.15V (-10.24V)	27	-8.43V (-8.51V)
14	-10.15V (-10.24V)	28	-8.43V (-8.50V)

Q9 [2SD636]		Q10 [2SD592]	
B	-5.57V (-5.63V)	B	-9.89V (-10.36V)
C	-10.17V (-10.27V)	C	-4.49V (-10.36V) CrO ₂ : -1.93V Nor: 2.34V
E	-	E	-10.13V (-10.36V)

Q11 [2SB641]		Q12 [2SD636]	
B	12.46V (13.28V) C/R 12.01V	B	0V (0V) STOP 0.64V
C	-0.20V (-0.20V) 12.70V	C	12.44V (13.30V) 0.01V
E	12.46V (13.28V) 12.75V	E	0V (0V) 0V

Q13 [2SB641]		Q14 [2SC1846R]	
B	12.53V (12.35V) STOP 11.50V	B	11.16V (11.34V)
C	-10.0V (-10.7V) 12.0V	C	12.74V (13.50V)
E	12.53V (13.30V) 12.15V	E	10.46V (10.65V)

Q15 [2SA885Q]	
B	-11.01V (-11.04V)
C	-12.23V (-13.14V)
E	-10.31V (-10.38V)

NOTES:

- The circuit shown in [] on the onductor indicates printed circuit on the back side of the printed circuit board.
- Values indicated in [] are under no signal condition.

Unless otherwise specified, voltage measurement conditions are the tape travel is at STOP, tape mode at NORMAL, and Dolby NR switch at OFF.

RECVoltage at record mode.
 PLAYVoltage at playback mode.
 REC/PLAYVoltage at record/playback mode.
 NormalVoltage at Normal tape mode.
 CrO₂Voltage at CrO₂ tape mode.
 MetalVoltage at Metal tape mode.
 STOPVoltage at STOP mode.
 C/RVoltage at Cue/Review mode.
 BVoltage at Dolby-B mode.
 CVoltage at Dolby-C mode.

For measurement, use VTVM.

- The supply parts number is described alone in the replacement parts list.
- This circuit board diagram may be modified at any time with the development of new technology.

TERMINATIONS

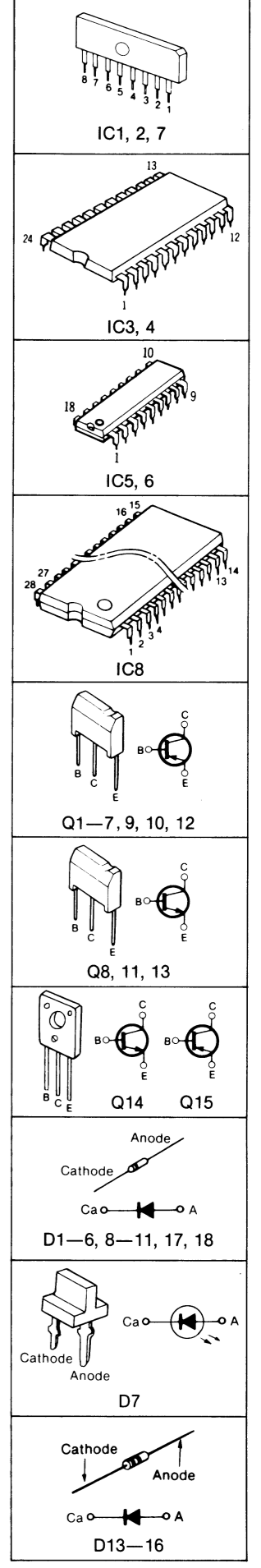

REPLACEMENT PARTS LIST

MECHANICAL PARTS LOCATION

A
B
C
D
E
F

Ref No.	Part No.	Part Name & Description
MECHANICAL PARTS		
M 1	QBP1874	Cassette Pressure Spring
M 2	QDG1201	Main Gear
M 3	QDG1202	Sub Gear
M 4	QMB1336	Supply Reel Table Hub
M 5	QDR1139	Supply Reel Table
M 6	QMF2118	Fast Forward Arm Bracket
M 7	QML3899	Sub Control Lever
M 8	QML3898	Main Control Lever
M 9	QML3900	Record Operation Lever
M 10	QML3586	Head Base Plate Lift Lever
M 11	QML3594	Auto-Stop Release Arm
M 12	QML3603	Erase Safety Lever
M 13	QML3604	Auto-Stop Driving Lever
M 14	QML3605	Auto-Stop Detection Lever
M 15	QML3592	Change Lever
M 16	QMR2013	Record Rod
M 17	QMR2011	Auto-Stop Connection Rod
M 18	QMR2014	Eject Rod
M 19	QMR2012	Control Rod
M 20	QMZ1283	Flywheel Thrust Retainer
M 21	QBC1357	Lock Pin Pressure Spring
M 22	QML3896	Auto-Stop Selection Lever
M 23	QBT1962	Main Lever Spring
M 24	QBN1739	Selection Lever Spring
M 25	QBN1742	Pressure Roller Release Spring
M 26	QBN1744	Sub Gear Spring
M 27	QBN1897	Main Gear Spring
M 28	QBN1746	Auto-Stop Lever Spring
M 29	QBN1747	Connection Spring
M 30	QBS1137	Pause Lock Pin
M 31	QBC1372	Reel Table Spring
M 32	QBW2008	Poly Washer
M 33	QBT1961	Operating Change Lever Spring
M 34	XUB3FT	Stop Ring 3ø
M 35	QBW2012	Poly Washer
M 36	QXL1354	Sub Lever Assembly
M 37	QXL1355	Main Lever Assembly
M 38	QML3882	Pause Change Lever
M 39	QBT1682	Lock Retainer Spring
M 40	QXL1381	Pressure Roller Assembly
M 41	QBN1743	Pressure Roller Spring
M 42	QML3588	Fast Forward Lever
M 43	QBN1748	Fast Forward Spring
M 44	QMA4410	Flywheel Retainer
M 45	XSN2 + 10	Screw $\varnothing 2 \times 10$
M 46	QBN1741	Change Lever Spring
M 47	XWG2B	Washer 2ø
M 48	QMZ1254	Cord Clamper
M 49	QXF0199	Flywheel Assembly
M 49-1	QBW2049	Poly Washer
M 49-2	QBW2026	Snap Ring
M 50	QXD1143	Takeup Reel Table Assembly
M 51	QXL1382	Idler Lever Assembly
M 52	QXi0111	Takeup Idler Assembly
M 53	QBT1893	Takeup Idler Spring
M 54	QXi0113	Fast Forward Idler Assembly
M 55	QXi0112	Rewind Idler Assembly
M 56	QXL1383	Fast Forward Arm Assembly
M 57	QMK1840	Head Base Plate
M 58	QMZ1241	Head Spacer
M 59	QBN1740	Head Pressure Spring
M 60	QBC1278	Head Spring
M 61	QBCA0008	Head Spring
M 62	QML3591	Brake Arm
M 63	QMZ1240	Sub Head Base Plate
M 64	QMN2550	Roller
M 65	QDK1017	Steel Ball 2ø
M 66	QBP1873	Head Base Plate Pressure Spring
M 67	QBT1597	Brake Arm Spring
M 68	QBT1892	Head Release Spring
M 69	QMA3858	Head Adjustment Plate
M 70	QZK0241	Takeup Gear Assembly
M 71	QXU0297	Motor Assembly
M 72	QXK2286	Sub Chassis Assembly
M 73	QDG1199	Auto-Stop Gear
M 74	QDG1200	Cam Gear
M 75	XWG2	Washer 2ø
M 76	QDB0324	Capstan Belt
M 77	QDB0274	Takeup Belt
M 78	QDB0273	Fast Forward Belt
M 79	QXL1360	Record/Playback Selection Arm Assembly
M 80	QML3580	Record/Playback Selection Lever
M 81	QBT1895	Record/Playback Selection Lever Spring
M 82	QXP0607	Fast Forward Connection Pulley Assembly
M 83	QMK1838	Upper Base Plate
M 85	QDP1828	Fast Forward Pulley
M 86	QXH0408	Chassis Cover Assembly
M 87	QDC0126	Tape Counter
M 88	QDB0169	Counter Belt
M 89	QMA4439	Counter Angle
M 90	XTN3 + 24B	Tapping Screw $\varnothing 3 \times 24$
M 91	XSN26 + 3	Screw $\varnothing 2.6 \times 3$
M 92	XTN2 + 6B	Tapping Screw $\varnothing 2 \times 6$
M 93	XTN26 + 6B	Tapping Screw $\varnothing 2.6 \times 6$
M 94	XTN26 + 10B	Tapping Screw $\varnothing 2.6 \times 10$
M 95	XTN26 + 12B	Tapping Screw $\varnothing 2.6 \times 12$
M 96	XTN3 + 10B	Tapping Screw $\varnothing 3 \times 10$
M 97	XTN26 + 5BFZ	Tapping Screw $\varnothing 2.6 \times 5$
M 99	QML3885	Fast Forward Driving Lever
M 100	QML3886	Rewind Driving Lever
M 101	QML3887	Record Driving Lever
M 102	QML3897	Play Changing Lever
M 103	QML3901	Eject Obstruction Lever
M 104	QMR2007	Fast Forward Connection Plate
M 105	QMR2008	Rewind Connection Plate
M 106	QMR2009	Record Connection Plate
M 107	QMZ1288	Connection Plate Retainer
M 108	QMA4411	Holding Angle-L
M 109	QMA4412	Holding Angle-R
M 110	QDG1254	Damper Gear
M 111	QDP1920	Damper Retainer
M 112	QML3878	Fast Forward Change Lever
M 113	QML3879	Rewind Change Lever
M 114	QML3880	Record Change Lever
M 115	QML3881	Play Change Lever
M 116	QML3883	Lock Arm-A
M 117	QML3884	Lock Arm-B
M 118	QML3888	Play Lever
M 119	QML3889	Stop lever
M 120	QML3890	Fast Forward Lever
M 121	QML3891	Rewind Lever
M 122	QML3892	Record Lever
M 123	QML3893	Pause Lever
M 124	QML3894	Muting Lever
M 125	QMR2006	Fast Wind Rod
M 126	QMR2010	Pause Rod
M 127	QMF2245	Operating Button Plate
M 128	QKJ0537	Operating Button Frame
M 129	QBP1953	Operating Lever Spring
M 130	QBN1898	Fast Wind Rod Spring
M 131	QBW2020	Washer
M 132	XWG26	Washer 2.6ø
M 133	XTN2 + 5B	Tapping Screw $\varnothing 2 \times 5$
M 134	XTN2 + 4BFZ	Tapping Screw $\varnothing 2 \times 4$
M 135	XTN3 + 6B	Tapping Screw $\varnothing 3 \times 6$
M 136	XTN3 + 12B	Tapping Screw $\varnothing 3 \times 12$
M 137	QJT0015	Lug Terminal

• Front View

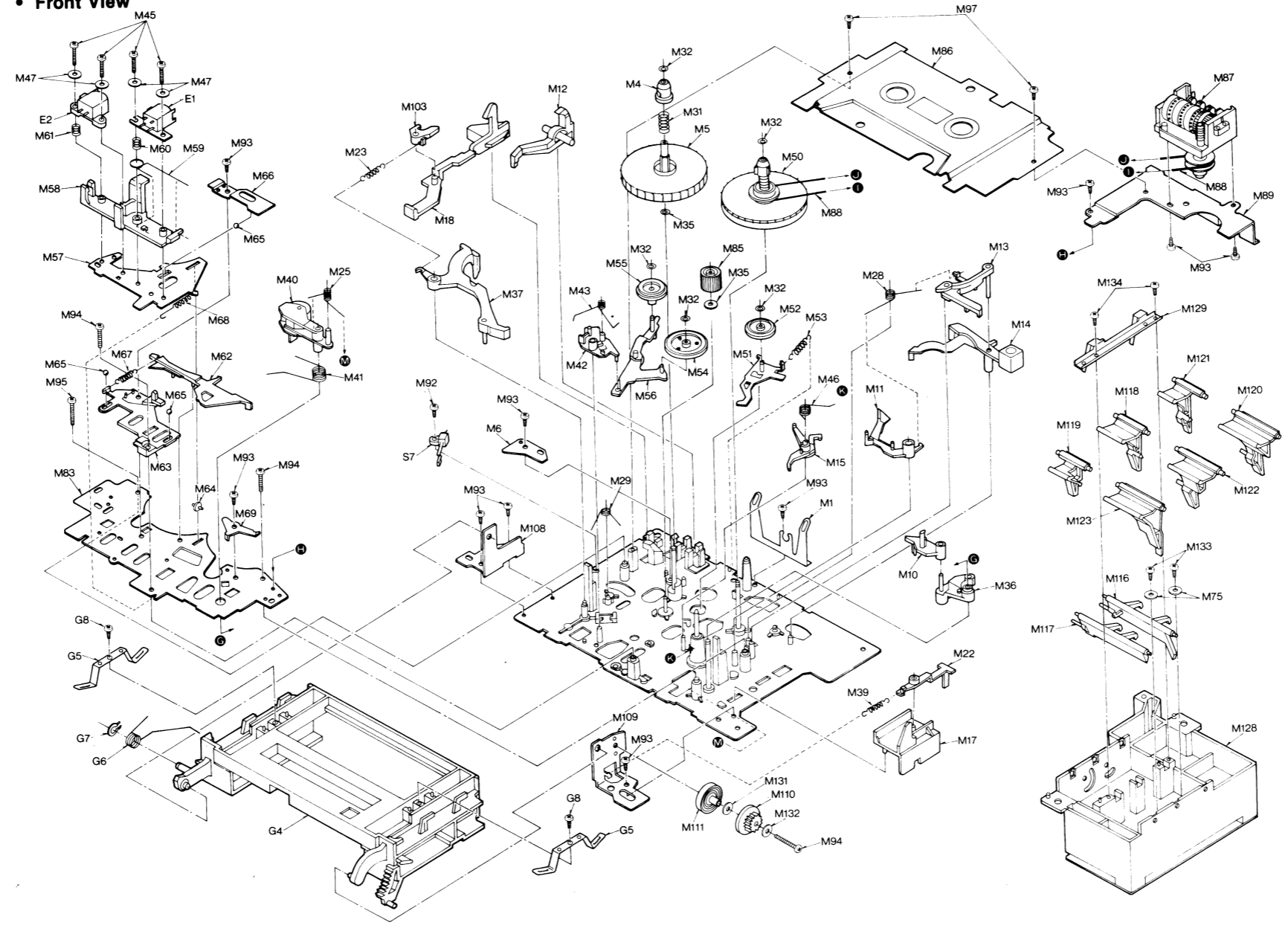

• Rear View

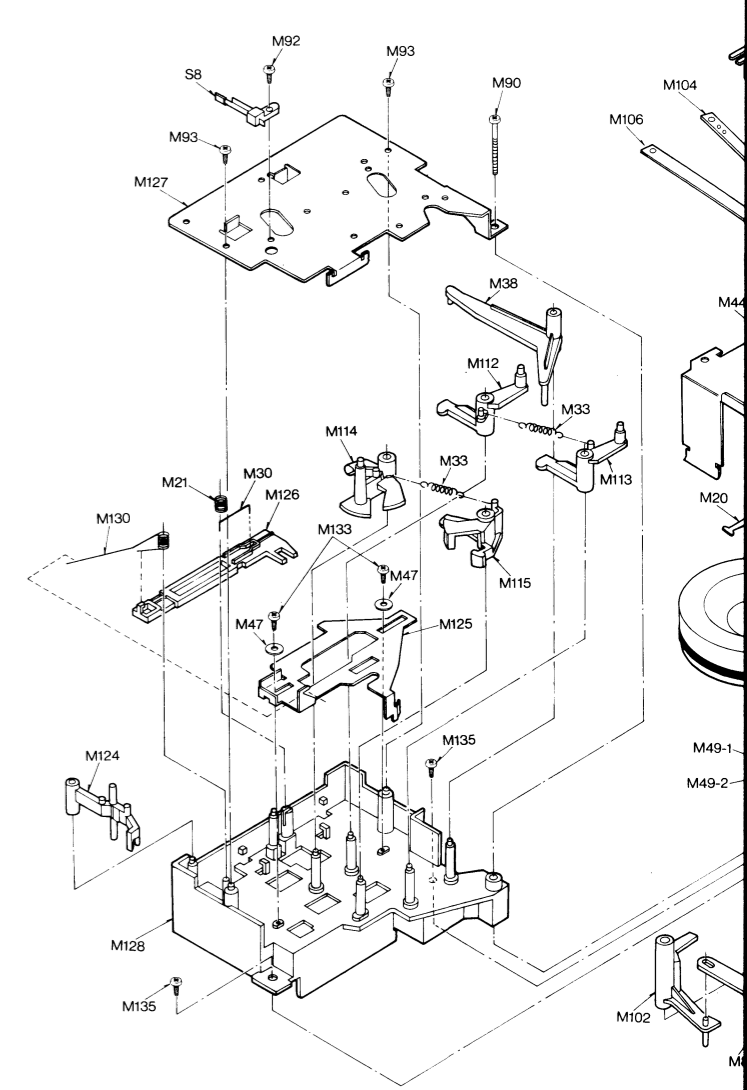

Ref No.	Part No.	Part Name & Description	Ref No.	Part No.	Part Name & Description	Ref No.	Part No.	Part Name & Description
M 78	QDB0273	Fast Forward Belt	M 97	XTN26 + 5BFZ	Tapping Screw $\varnothing 2.6 \times 5$	M 117	QML3884	Lock Arm-B
M 79	QXL1360	Record/Playback Selection Arm Assembly	M 99	QML3885	Fast Forward Driving Lever	M 118	QML3888	Play Lever
M 80	QML3580	Record/Playback Selection Lever	M 100	QML3886	Rewind Driving Lever	M 119	QML3889	Stop lever
M 81	QBT1895	Record/Playback Selection Lever Spring	M 101	QML3887	Record Driving Lever	M 120	QML3890	Fast Forward Lever
M 82	QXP0607	Fast Forward Connection Pulley Assembly	M 102	QML3897	Play Changing Lever	M 121	QML3891	Rewind Lever
M 83	QMK1838	Upper Base Plate	M 103	QML3901	Eject Obstruction Lever	M 122	QML3892	Record Lever
M 85	QDP1828	Fast Forward Pulley	M 104	QMR2007	Fast Forward Connection Plate	M 123	QML3893	Pause Lever
M 86	QXH0408	Chassis Cover Assembly	M 105	QMR2008	Rewind Connection Plate	M 124	QML3894	Muting Lever
M 87	QDC0126	Tape Counter	M 106	QMR2009	Record Connection Plate	M 125	QMR2006	Fast Wind Rod
M 88	QDB0169	Counter Belt	M 107	QMZ1288	Connection Plate Retainer	M 126	QMR2010	Pause Rod
M 89	QMA4439	Counter Angle	M 108	QMA4411	Holding Angle-L	M 127	QMF2245	Operating Button Plate
M 90	XTN3 + 24B	Tapping Screw $\varnothing 3 \times 24$	M 109	QMA4412	Holding Angle-R	M 128	QKJ0537	Operating Button Frame
M 91	XSN26 + 3	Screw $\varnothing 2.6 \times 3$	M 110	QDG1254	Damper Gear	M 129	QBP1953	Operating Lever Spring
M 92	XTN2 + 6B	Tapping Screw $\varnothing 2 \times 6$	M 111	QDP1920	Damper Retainer	M 130	QBN1898	Fast Wind Rod Spring
M 93	XTN26 + 6B	Tapping Screw $\varnothing 2.6 \times 6$	M 112	QML3878	Fast Forward Change Lever	M 131	QBW2020	Washer
M 94	XTN26 + 10B	Tapping Screw $\varnothing 2.6 \times 10$	M 113	QML3879	Rewind Change Lever	M 132	XWG26	Washer 2.6ø
M 95	XTN26 + 12B	Tapping Screw $\varnothing 2.6 \times 12$	M 114	QML3880	Record Change Lever	M 133	XTN2 + 5B	Tapping Screw $\varnothing 2 \times 5$
M 96	XTN3 + 10B	Tapping Screw $\varnothing 3 \times 10$	M 115	QML3881	Play Change Lever	M 134	XTN2 + 4BFZ	Tapping Screw $\varnothing 2 \times 4$
			M 116	QML3883	Lock Arm-A	M 135	XTN3 + 6B	Tapping Screw $\varnothing 3 \times 6$
						M 136	XTN3 + 12B	Tapping Screw $\varnothing 3 \times 12$
						M 137	QJT0015	Lug Terminal

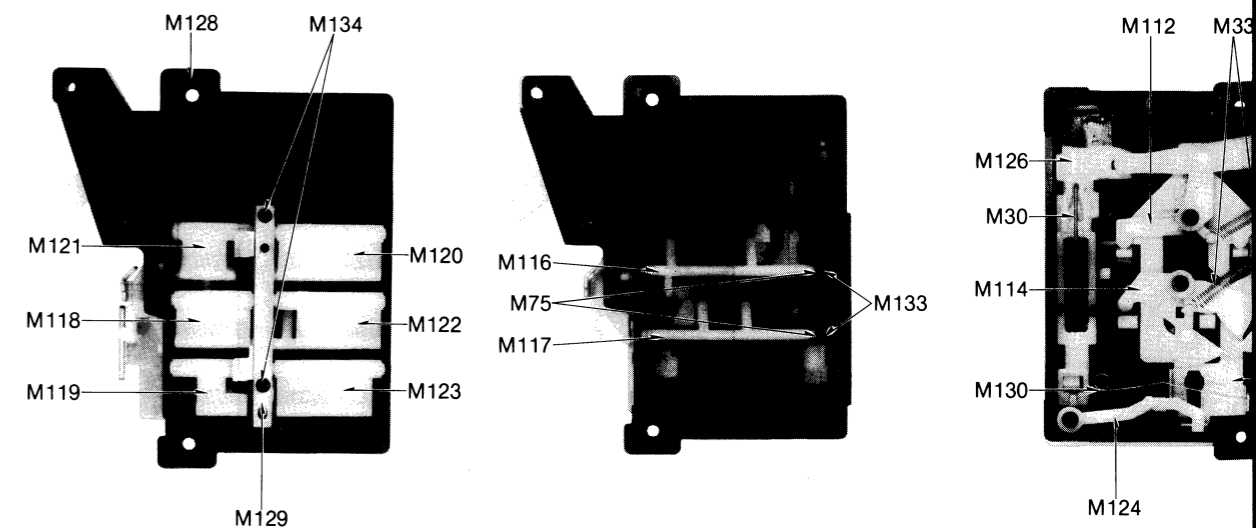

ICATION

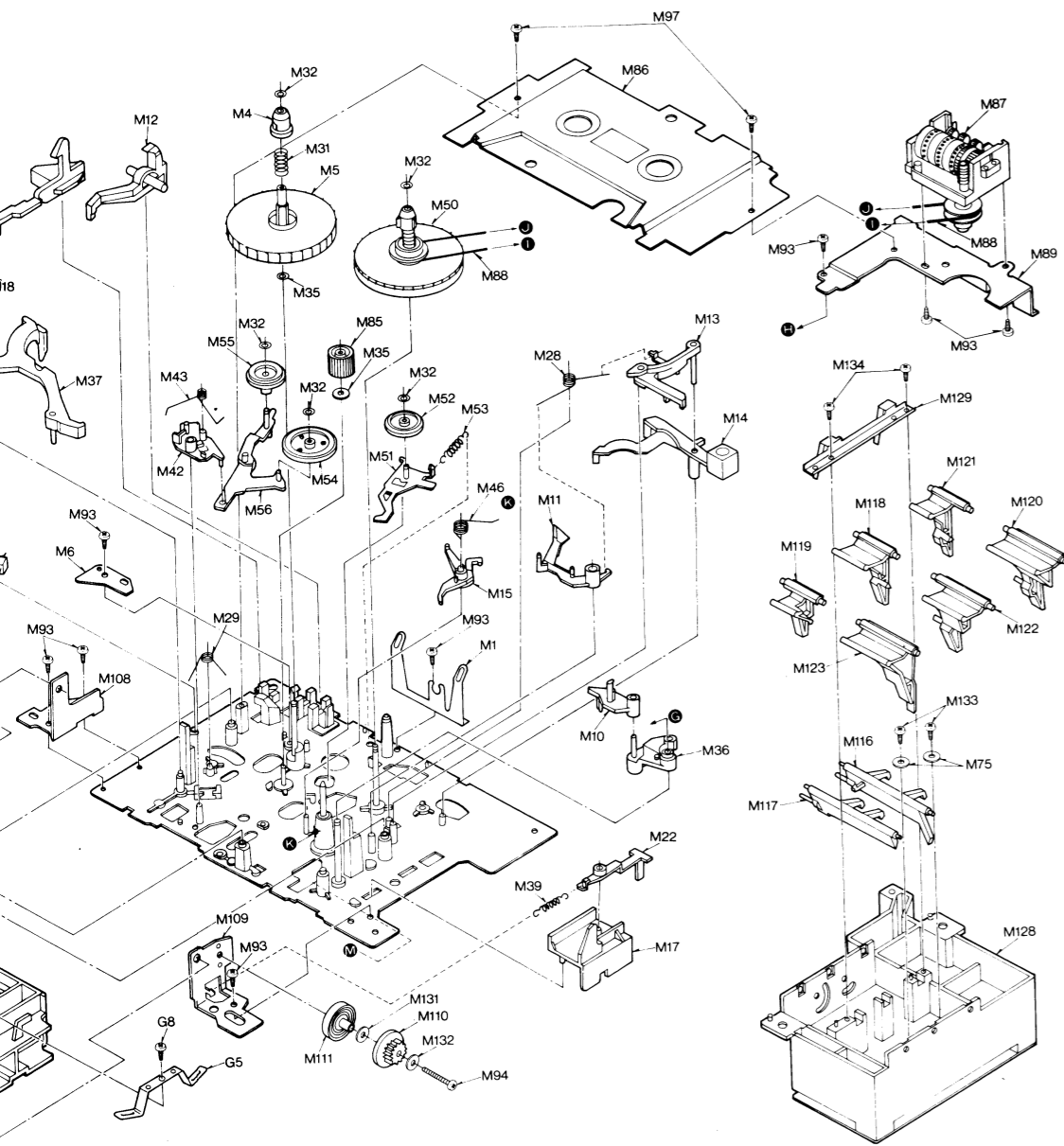

• Rear View

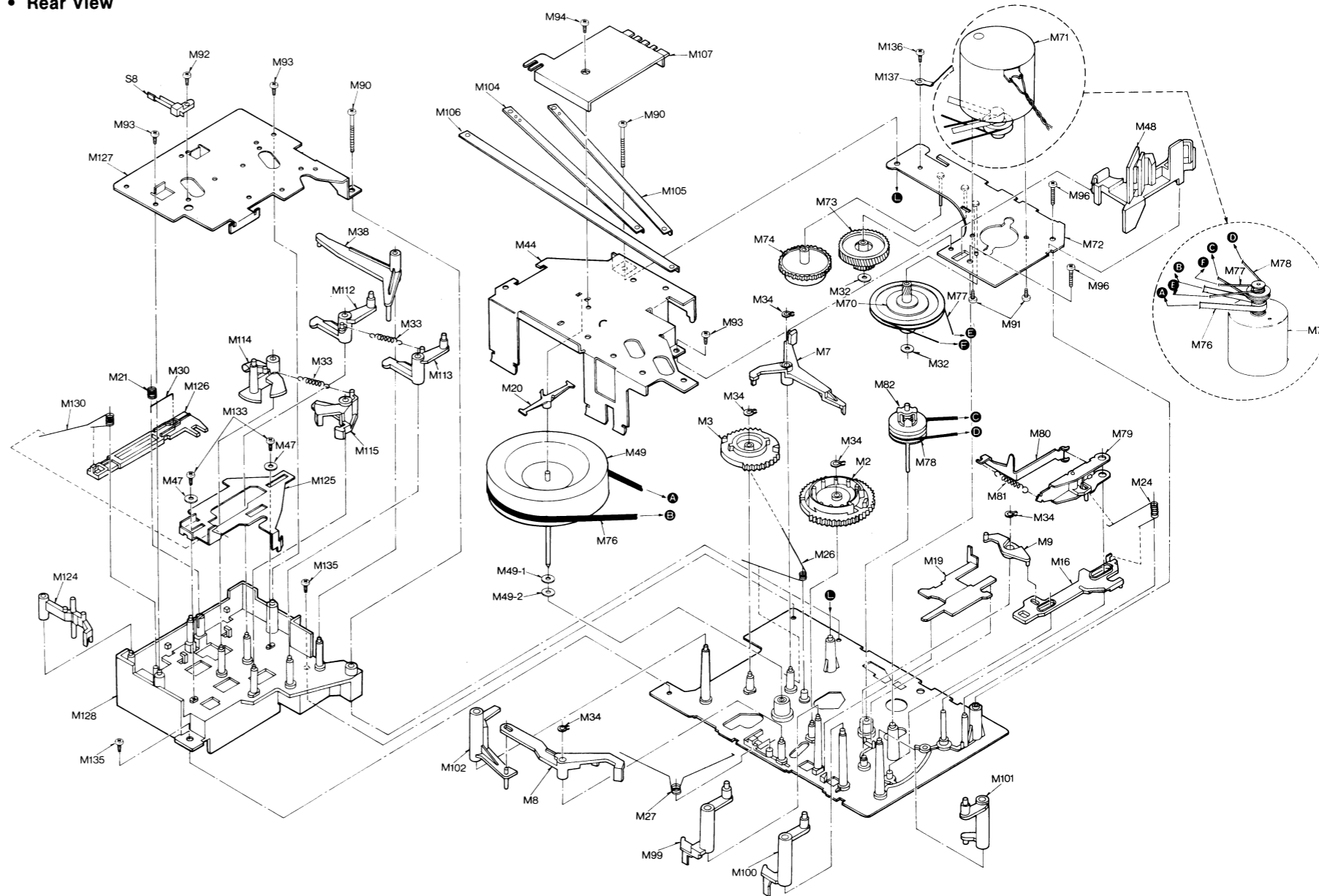

Part Name & Description	Ref No.	Part No.	Part Name & Description
...ing Screw @2.6x5	M 117	QML3884	Lock Arm-B
...per Retainer	M 118	QML3888	Play Lever
...t Forward Driving Lever	M 119	QML3889	Stop lever
...ind Driving Lever	M 120	QML3890	Fast Forward Lever
...ord Driving Lever	M 121	QML3891	Rewind Lever
...y Changing Lever	M 122	QML3892	Record Lever
...ct Obstruction Lever	M 123	QML3893	Pause Lever
...t Forward Connection	M 124	QML3894	Muting Lever
...e	M 125	QMR2006	Fast Wind Rod
...ind Connection Plate	M 126	QMR2010	Pause Rod
...ord Connection Plate	M 127	QMF2245	Operating Button Plate
...nection Plate Retainer	M 128	QKJ0537	Operating Button Frame
...ding Angle-L	M 129	QBP1953	Operating Lever Spring
...ding Angle-R			
...per Gear	M 130	QBN1898	Fast Wind Rod Spring
...per Retainer	M 131	QBW2020	Washer
...t Forward Change	M 132	XWG26	Washer 2.6φ
...er	M 133	XTN2 + 5B	Tapping Screw @2 x 5
...ind Change Lever	M 134	XTN2 + 4BFZ	Tapping Screw @2 x 4
...ord Change Lever	M 135	XTN3 + 6B	Tapping Screw @3 x 6
...y Change Lever	M 136	XTN3 + 12B	Tapping Screw @3 x 12
...k Arm-A	M 137	QJT0015	Lug Terminal

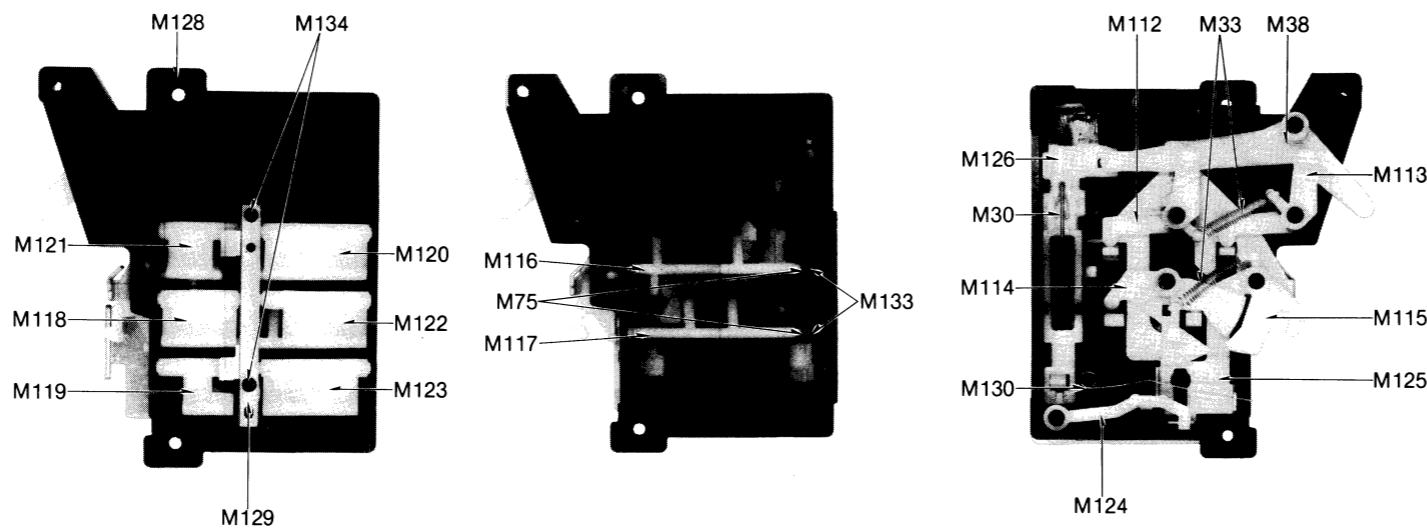

When servicing this mechanism unit, refer to the disassembly notes and assembly instructions described in the service manuals of RS-M51, RS-M13, RS-M14 and RS-M04 (RS-M24 mechanism series).

SPECIFICATIONS

Pressure of pressure roller	350 ± 50 g
Takeup tension * Use cassette torque meter ... QZZSRKCT	45 + 15 - 15 g·cm
Wow and flutter: (JIS) * Use test tape ... QZZCWAT	Less than 0.08% (WRMS)

Motor Unit Disassembly

1. Remove screw (A) and connection plate retainer (M107). The remove fast forward connection plate (M104), rewind connection plate (M105) and record connection plate (M106) (see Fig. 1).
2. Remove three screws (B) and remove operation button unit (see Fig. 2).
3. Remove two screws (C) and hook at section (D) to dismount flywheel retainer (M44) (see Fig. 2).
4. Remove hook at section (E) and cord clammer (M48) (see Fig. 2), and then remove two screws (F) (see Fig. 3) to dismount motor unit.

Precautions for Mechanism Unit Assembly

Before installing the operation button unit in the mechanism unit, pull the play changing lever (M102) of the mechanism unit in the direction of the arrow until it is locked, and set the pause, F.F. and rewind buttons of the operation button unit to OFF. At this time, check that all parts are installed at their proper positions at sections (G), (H) and (I) (see Fig. 2).

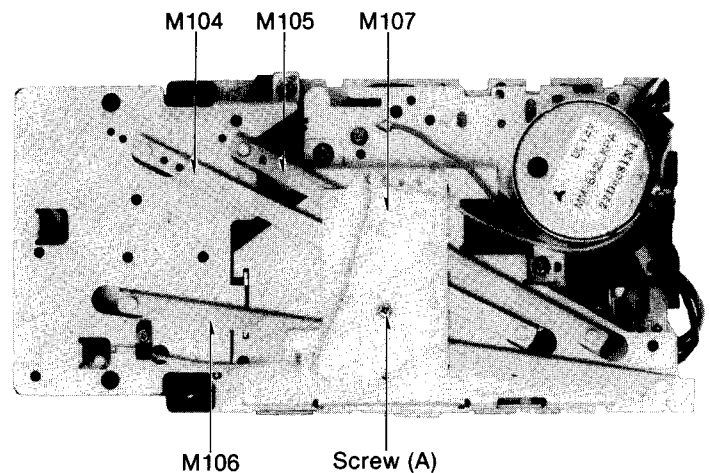

Fig. 1

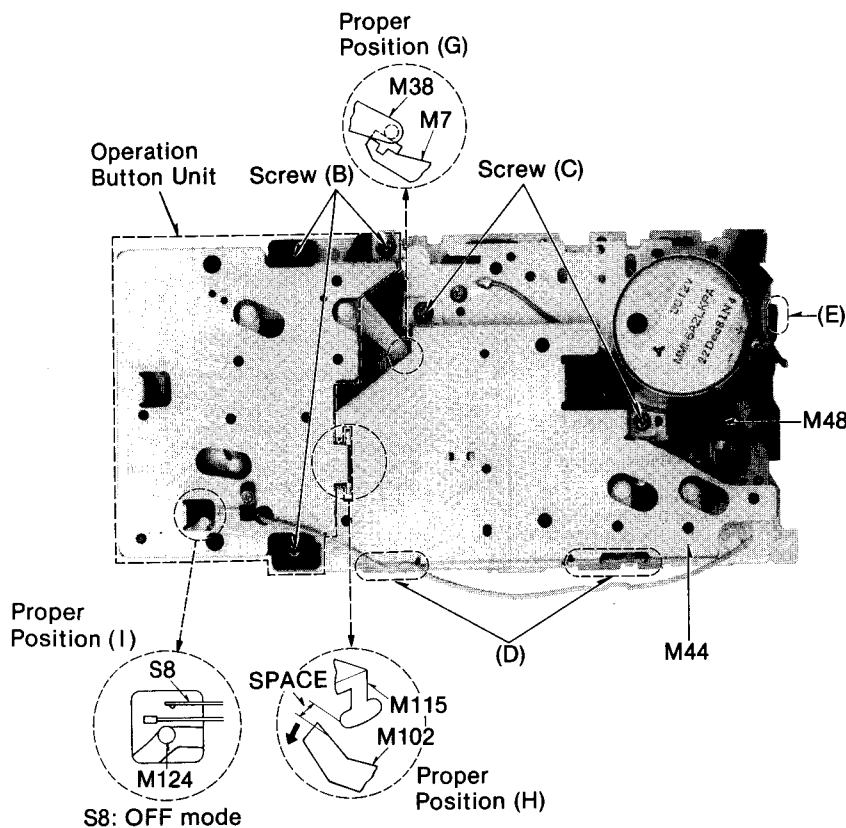

Fig. 2

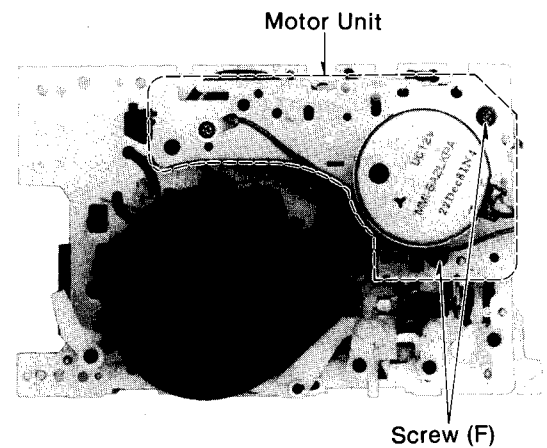
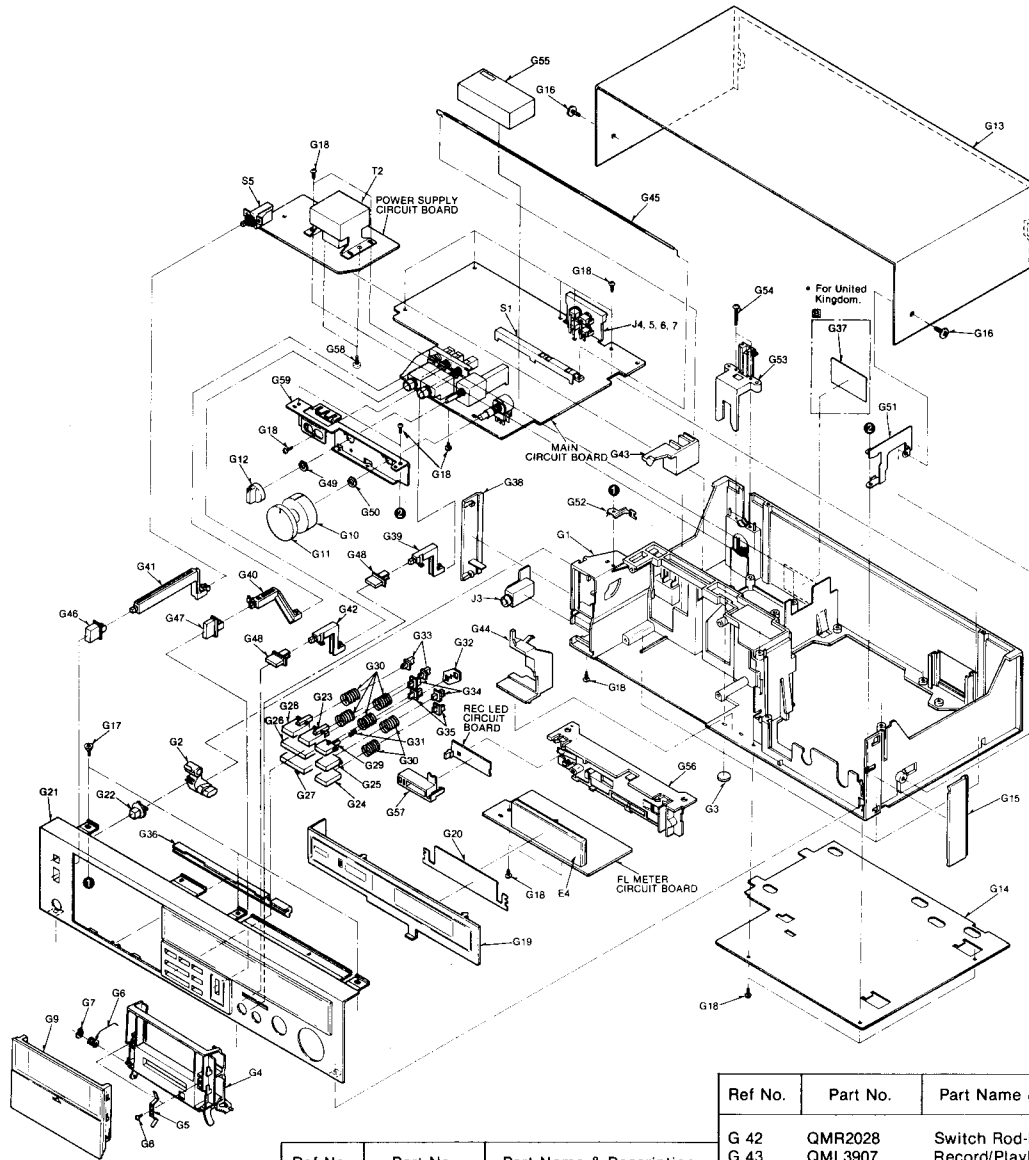

Fig. 3

CABINET PARTS LOCATION



REPLACEMENT PARTS LIST

Ref No.	Part No.	Part Name & Description
CABINET PARTS		
G 1	QKM1535K	Main Case
G 2	QML3908	Eject Lever
G 3	QKA1081	Rubber Foot
G 4	QKF2105	Cassette Holder
G 5	QBP1923	Holder Spring
G 6	QBN1893	Eject Spring
G 7	XUB5FT	Stop Ring 5φ
G 8	XTN26 + 5BFZ	Tapping Screw $\varnothing 2.6 \times 5$
G 9	QYF0560	Cassette Lid Assembly
	"Silver Type"	
	QYF0560K	Cassette Lid Assembly
	"Black Type"	
G 10	QYT0647	Volume Knob-R Assembly
G 11	QYT0648	Volume Knob-L Assembly
G 12	QGT1591	Tape Selector Knob
G 13	QGC1231	Case Cover
	"Silver Type"	
	QGC1231K	Case Cover
	"Black Type"	
G 14	QGC1232	Bottom Cover
G 15	QGK3260	Side Panel-R
	"Silver Type"	
	QGK3260K	Side Panel-R
	"Black Type"	
G 16	QHQ1324	Screw
	"Silver Type"	
	QHQ1324K	Screw
	"Black Type"	
G 17	XTS3 + 10B	Tapping Screw $\varnothing 3 \times 10$

Ref No.	Part No.	Part Name & Description
G 18	XTN3 + 10B	Tapping Screw $\varnothing 3 \times 10$
G 19	QGK3263	Meter Cover
	"Silver Type"	
	QGK3263Y	Meter Cover
	"Black Type"	
G 20	QGL1177	Meter Filter
G 21	QYP1110	Front Panel Assembly
	"Silver Type"	
	QYP1110K	Front Panel Assembly
	"Black Type"	
G 22	QGO2059	Eject Button
G 23	QGOM0089	Fast Forward Button
G 24	QGOM0095	Pause Button
G 25	QGOM0093	Record Button
G 26	QGOM0092	Playback Button
G 27	QGOM0094	Stop Button
G 28	QGOM0088	Rewind Button
G 29	QGOM0097	Counter Reset Button
G 30	QBC1414	Button Spring
G 31	QBC1187	Idle Spring
G 32	QKJ0547	Spring Holder
G 33	QKJ0544	Button Rod-A
G 34	QKJ0545	Button Rod-B
G 35	QKJ0546	Button Rod-C
G 36	QKJ3529K	Spacer
G 37 [B]	QGS2994	Main Name Plate
	[For United Kingdom.]	
G 38	QGK3286	Side Panel-L
	"Silver Type"	
	QGK3286K	Side Panel-L
	"Black Type"	
G 39	QMR2026	Switch Rod-D
G 40	QMR2027	Switch Rod-E
G 41	QMR2019	Switch Rod-C

Ref No.	Part No.	Part Name & Description
G 42	QMR2028	Switch Rod-F
G 43	QML3907	Record/Playback Lever
G 44	QML3909	Counter Reset Lever
G 45	QBS1139	Record/Playback Connection Wire
G 46	QGO1900	Power ON/OFF Button
G 47	QGO2052	Push Button-B
G 48	QGO2071	Push Button-C
G 49	XNS8	Nut 8φ
G 50	XNS9	Nut 9φ
G 51	QJC0054	Earth Plate-A
G 52	QJC0057	Earth Plate-C
G 53	QKJ0550K	Cord Clamper
G 54	XTN3 + 20B	Tapping Screw $\varnothing 3 \times 20$
G 55	QTS1586	Shield Case
G 56	QKJ0548	Meter Holder
G 57	QKJ0549	LED Holder
G 58	XTN3 + 8B	Tapping Screw $\varnothing 3 \times 8$
G 59	QMA4440	Volume Angle
ACCESSORIES		
A 1	QEB0125	Connection Cord
A 2 [D]	QQT3331	Instruction Book
	[For all European areas except United Kingdom.]	
	[B] QQT3310	Instruction Book
	[For United Kingdom.]	
PACKINGS		
P 1	QPN4332	Inside Carton
P 2	QPA0676	Cushion-R
P 3	QPA0675	Cushion-L
P 5	QPC0072	Poly Sheet
	(for AC Power Cord)	
P 6	XZB40X60A02	Poly Bag (for UNIT)



Service Manual

Cassette Deck

Soft-Touch Cassette Deck
with Dolby B-C NR

RS-M226

(Black Face)
(Silver Face)

Supplement-2



This is the Service Manual
for the following areas.

D ...For all European
areas except United
Kingdom.

B ...For United Kingdom.

RS-M24 MECHANISM SERIES

Please use this manual together with the service manual for
model No. RS-M226 (Original) order No. ARD82060161C8-11 and
RS-M226 (Supplement-1) order No. ARD82100161S2-01.

PARTS COMPARISON TABLE:

Please revise the original parts list in the Service Manual (RS-M226) to conform to the changes shown herein.
If new part numbers are shown, be sure to use them when ordering parts.

Ref. No.	Part Name & Description	Part Numbers		Remarks
		Former Type	New Type	
G3	Rubber Foot	QKA1081	QKA1093	
G6	Eject Spring	QBN1893	QBN1937	
G37	Main Name Plate	—	QGS3094	Added

CIRCUIT BOARDS AND WIRING CONNECTION DIAGRAM

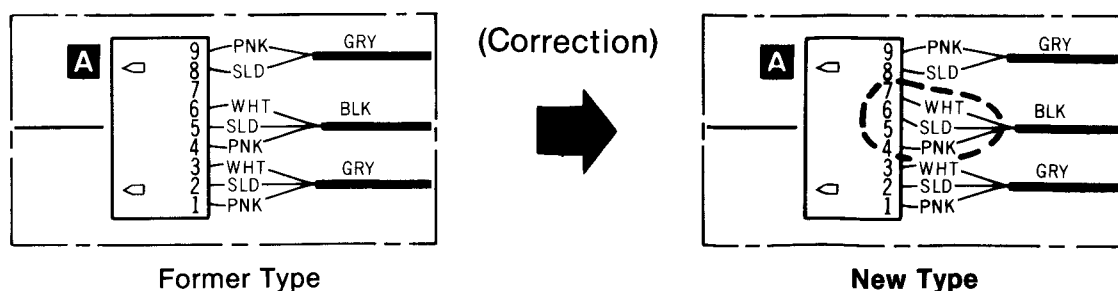

*'Dolby' and the double-D symbol are trademarks of Dolby Laboratories Licensing Corporation.

Technics

Matsushita Electric Trading Co., Ltd.
P.O. Box 288, Central Osaka Japan

(ARD, A.H) Printed in Japan